

“façon de venise[®]”

VENICE ITSELF

TWENTY_FIFTEEN



“façon de venise[®]”



CREATING LIGHT, DISCOVERING THE WORLD

Describing and discovering new places and fantasies, light effects, colours and refractions: new Façon de Venise creations are from the very heart of Venice and its traditions, offering attractive contemporary style.

SCOPRIRE IL MONDO,
DISEGNARE LA LUCE,

DISEGNARE LA LUCE,
SCOPRIRE IL MONDO

Raccontare e scoprire nuovi luoghi e fantasie,
giochi di luce, colori e rifrazioni:

dal respiro profondo di Venezia, delle sue storie,
ecco le nuove creazioni Façon de Venise,
per uno stile contemporaneo e coinvolgente.



INDEX

2_	20	PEANUT
25_	36	WILDLIGHT
38_	60	SEAHORSE
62_	97	MISSTRASS
100_	147	AQUA
148_	172	LIMELIGHT
176_	186	DRILL
188_	210	CHANDELIER
212_	234	BRICK
238_	252	BLOOM
254_	264	SINFONIA

PEANUT
design oriano favaretto



**PEANUT _ AP/PL 15 UP,
APPLIQUE IN FRASSINO/
WALL LAMP IN ASH WOOD**

DESIGN ORIANO FAVARETTO, 2014



PEANUT _ AP/PL 15 UP,
APPLIQUE IN FRASSINO/
WALL LAMP IN ASH WOOD

DESIGN ORIANO FAVARETTO, 2014

"CALLE", TYPICAL VENETIAN STREET _ 4.18 PM



**PEANUT _ AP/PL 15 DOWN,
PLAFONIERA IN FRASSINO/
CEILING LAMP IN ASH WOOD**

DESIGN ORIANO FAVARETTO, 2014



**PEANUT _ AP/PL 30 DOWN,
PLAFONIERA IN FRASSINO/
CEILING LAMP IN ASH WOOD**

DESIGN ORIANO FAVARETTO, 2014

**PEANUT _ AP/PL 30 UP,
PLAFONIERA IN FRASSINO/
CEILING LAMP IN ASH WOOD**

DESIGN ORIANO FAVARETTO, 2014



PEANUT SO,
SOSPENSIONE IN FRASSINO/
SUSPENDED LAMP IN ASH WOOD
DESIGN ORIANO FAVARETTO, 2014





**PEANUT_S0,
SOSPENSIONE IN FRASSINO/
SUSPENDED LAMP IN ASH WOOD**

DESIGN ORIANO FAVARETTO, 2014



PEANUT _ AP/PL 15 UP + KIT AP/PL UP,
APPLIQUE IN FRASSINO/
WALL LAMP IN ASH WOOD

DESIGN ORIANO FAVARETTO, 2014



PEANUT _ PL 70 DOWN,
PLAFONIERA IN FRASSINO/
CEILING LAMP IN ASH WOOD

DESIGN ORIANO FAVARETTO, 2014



Lampada in frassino. Lamp in ash wood. 7W LED GU10 

Colore naturale, bianco, marrone, grigio. Colour: natural, white, brown, grey.

Snodi in metallo cromato. Junctions in chrome finish metal.

Montatura in metallo bianco o nocciola. Fixture in painted metal. White or light brown.



Particolari in metallo: bianco, nocciola, giallo fluo, yellow fluo, orange fluo, green fluo, pink fluo, blue fluo.

Particolari in metallo: bianco, nocciola, giallo fluo, arancione fluo, verde fluo, rosa fluo, blu fluo.

7W LED GU10 

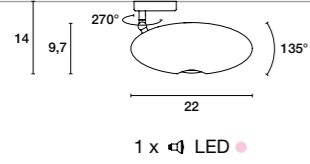

AP/PL 15 DOWN



1 x  LED 

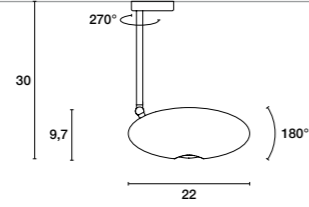

AP/PL 30 DOWN



1 x  LED 

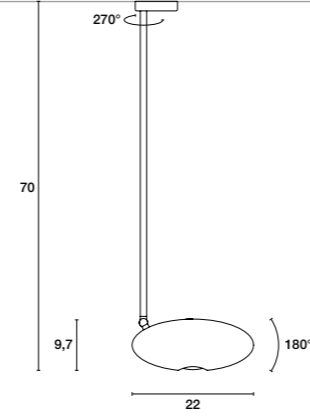

PL 70 DOWN



1 x  LED 

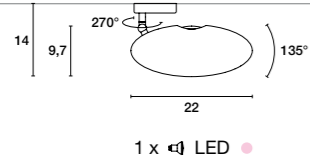

AP/PL 15 UP



1 x  LED 

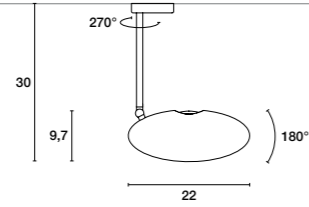

AP/PL 30 UP

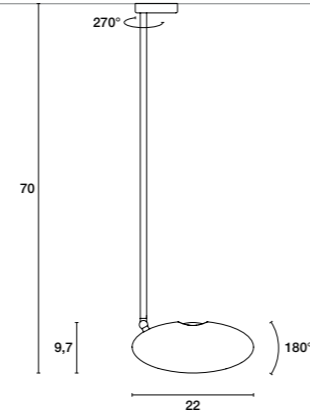

1 x  LED 

PL 70 UP



1 x  LED 

SO

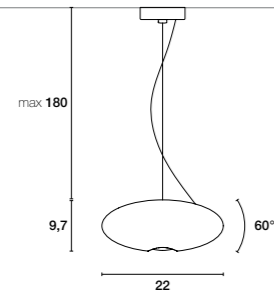

1 x  LED 

KIT AP/PL UP

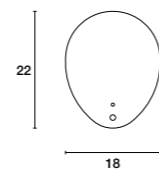

PEANUT
table of contents





design oriano favaretto
WIDLIGHT

WILDLIGHT _SO
SOSPENSIONE IN ROVERE NATURALE CON CAVO IN TESSUTO /
SUSPENDED LAMP IN OAK WITH CABLE IN FABRIC.

DESIGN ORIANO FAVARETTO, 2014





WILDLIGHT - SO
SOSPENSIONE IN ROVERE NATURALE CON CAVO IN TESSUTO/
SUSPENDED LAMP IN OAK WITH CABLE IN FABRIC

DESIGN ORIANO FAVARETTO, 2014

WILDLIGHT_TR
**LAMPADA DA TERRA IN ROVERE NATURALE CON CAVO IN TESSUTO/
FLOOR LAMP IN OAK WITH CABLE IN FABRIC**

DESIGN ORIANO FAVARETTO, 2014





WILDLIGHT_TR
LAMPADA DA TERRA IN ROVERE NATURALE CON CAVO IN TESSUTO/
FLOOR LAMP IN OAK WITH CABLE IN FABRIC

DESIGN ORIANO FAVARETTO, 2014



WILDLIGHT
design oriano favaretto

Lampada in rovere
con cavo in tessuto e sorgente LED.

Particolare rovere naturale
con cavo in tessuto marrone.
Particolare verniciato bianco
con cavo in tessuto bianco.
Particolare verniciato marrone
con cavo in tessuto marrone.
Particolare verniciato verde
con cavo in tessuto verde.

Lamp in natural oak
with cable in fabric and LED light source.

Detail in natural oak with cable in brown fabric.
White painted detail with cable in white fabric.
Brown painted detail with cable in brown fabric.
Green painted detail with cable in green fabric.

28.8W LED 220-240V 3000° K

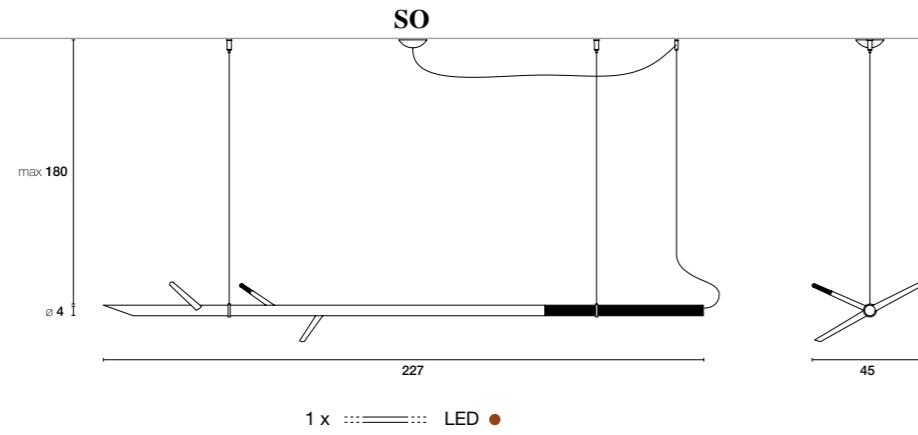

TR

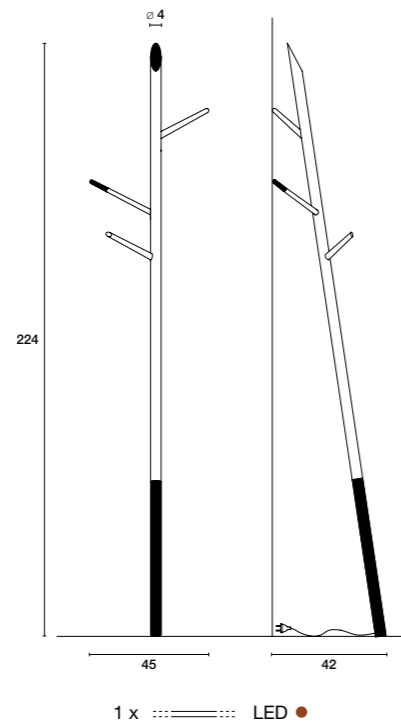



SEAHORSE

design romani sacconi architetti associati

SEAHORSE _ SO 2L/ SO 5L/ SO 8L
**LAMPADARIO IN TESSUTO ELASTICO/
CHANDELIER IN ELASTIC FABRIC**

DESIGN ROMANI SACCANI ARCHITETTI ASSOCIATI, 2013





SEAHORSE SO 8L
**LAMPADARIO IN TESSUTO ELASTICO/
CHANDELIER IN ELASTIC FABRIC**

DESIGN ROMANI SACCANI ARCHITETTI ASSOCIATI, 2013



SEAHORSE _ SO 81
LAMPADARIO IN TESSUTO ELASTICO /
CHANDELIER IN ELASTIC FABRIC

DESIGN ROMANI SACCANI ARCHITETTI ASSOCIATI, 2013

SEAHORSE_ SO 8L
LAMPADARIO IN TESSUTO ELASTICO /
CHANDELIER IN ELASTIC FABRIC

DESIGN ROMANI SACCANI ARCHITETTI ASSOCIATI, 2013



SEAHORSE_ SO 5L
LAMPADARIO IN TESSUTO ELASTICO/
CHANDELIER IN ELASTIC FABRIC

DESIGN ROMANI SACCANI ARCHITETTI ASSOCIATI, 2013





SEAHORSE _ AP 1L/ AP 2L
LAMPADARIO IN TESSUTO ELASTICO/
CHANDELIER IN ELASTIC FABRIC

DESIGN ROMANI SACCANI ARCHITETTI ASSOCIATI, 2013





SEAHORSE _ AP 2L
LAMPADARIO IN TESSUTO ELASTICO /
CHANDELIER IN ELASTIC FABRIC

DESIGN ROMANI SACCANI ARCHITETTI ASSOCIATI, 2013

SEAHORSE_ SO 5L
LAMPADARIO IN TESSUTO ELASTICO /
CHANDELIER IN ELASTIC FABRIC



DESIGN ROMANI SACCANI ARCHITETTI ASSOCIATI, 2013





Struttura metallo cromato. Rivestimento in tessuto elastico sfoderabile e lavabile. Colori: bianco, marrone, argento, oro, verde, grigio, camouflage.

Chrome metal structure. Removable and washable elastic fabric covering. Colors: white, brown, silver, gold, green, grey, camouflage.

12W E14  ●
42W E14  ●

SEAHORSE AP 1L

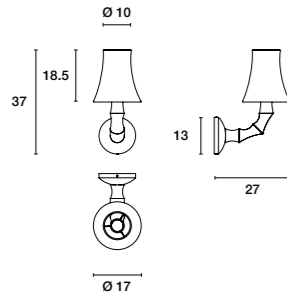

1 x  ● or 1 x  ●

SEAHORSE AP 2L

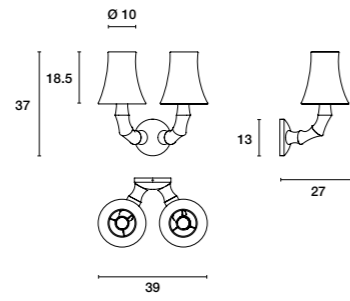

2 x  ● or 2 x  ●

SEAHORSE SO 2L

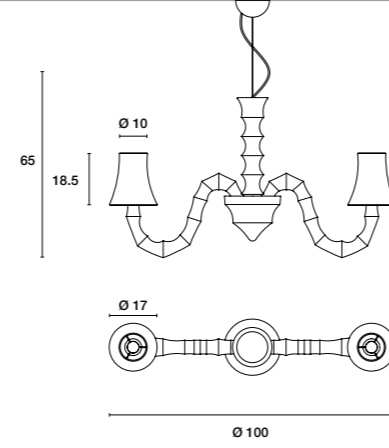

2 x  ● or 2 x  ●

SEAHORSE SO 5L

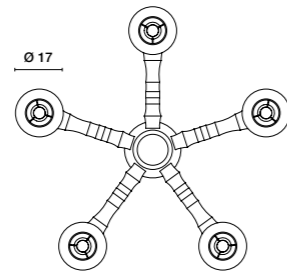
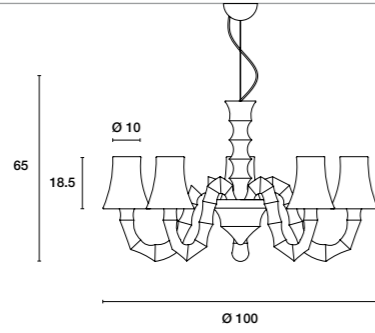

5 x  ● or 5 x  ●

SEAHORSE SO 8L

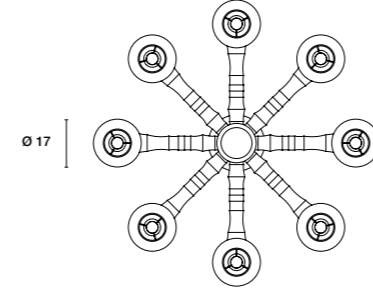
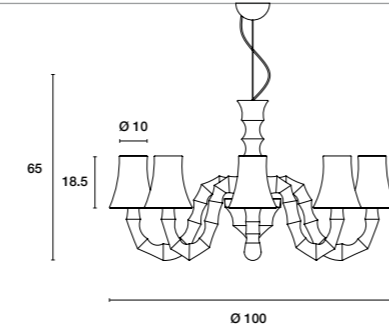

8 x  ● or 8 x  ●

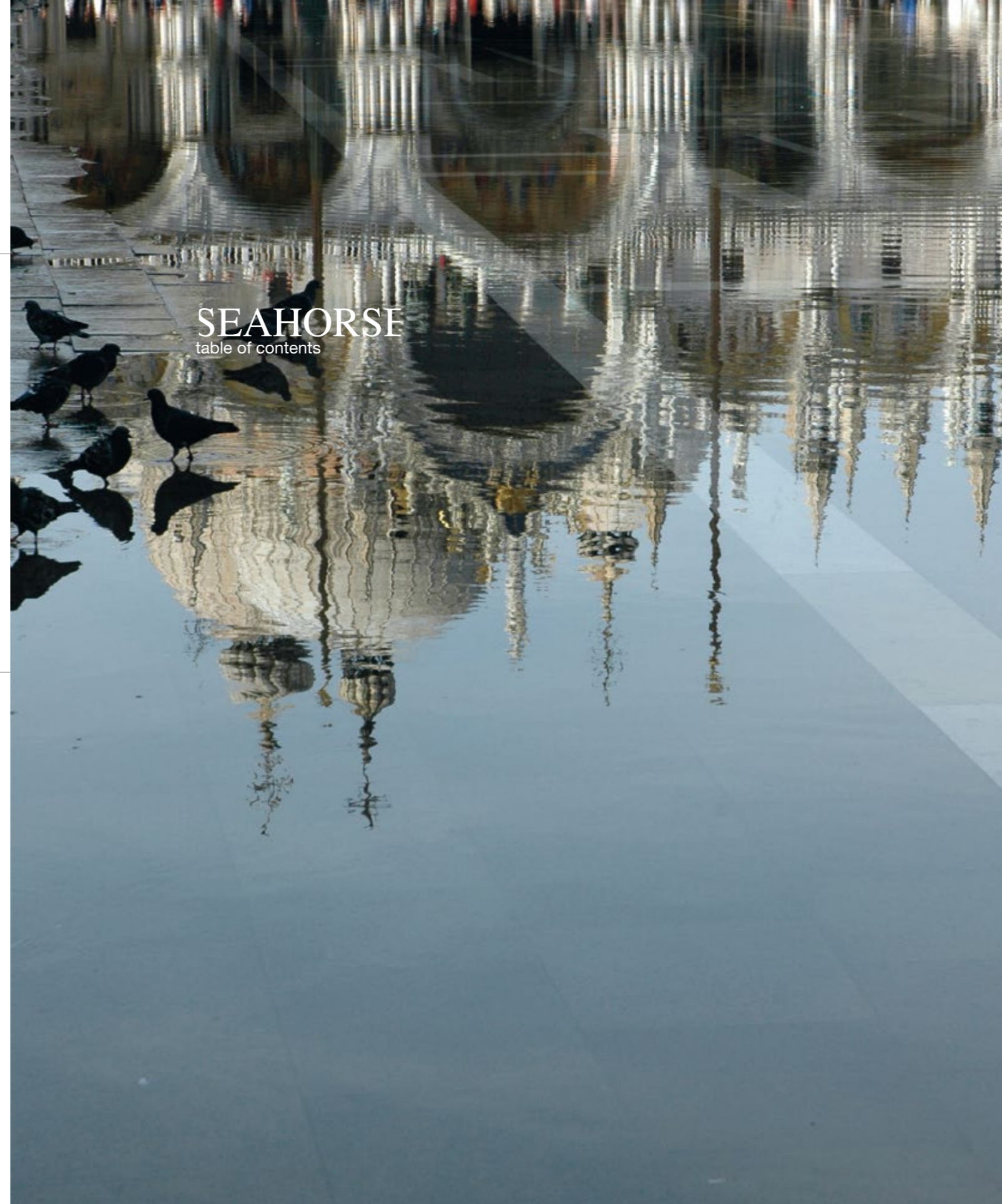



MISSTRASS

design mauro marzollo

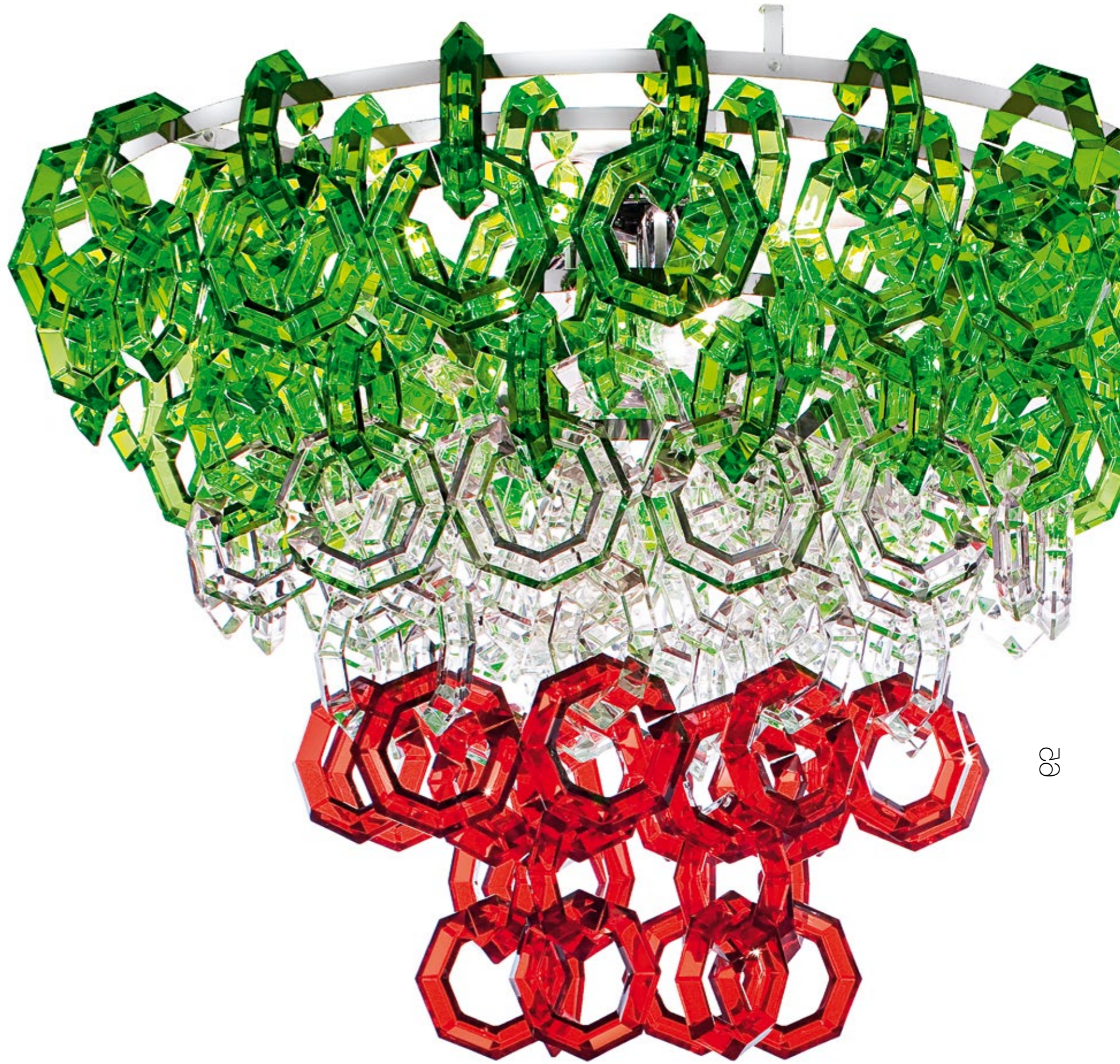

**MISSTRASS_PL100,
PLAFONIERA MODULARE IN PMMA/
MODULAR CEILING LAMP IN PMMA**

DESIGN MAURO MARZOLLO, 2008

MISSTRASS_PL70 L
PLAFONIERA MODULARE IN PMMA/
MODULAR CEILING LAMP IN PMMA

DESIGN MAURO MARZOLLO, 2008







MISSTRASS_PL70
PLAFONIERA MODULARE IN PMMA/
MODULAR CEILING LAMP IN PMMA

DESIGN MAURO MARZOLLO, 2008

MISSTRASS _ SO 70 CUSTOM
SOSPENSIONE MODULARE IN PMMA /
MODULAR SUSPENDED LAMP IN PMMA

MISSTRASS _ AP CUSTOM
APPLIQUE MODULARE IN PMMA /
MODULAR WALL LAMP IN PMMA

DESIGN MAURO MARZOLLO, 2008



74

FAÇON DE VENISE MISSTRASS

MISSTRASS P105
**PLAFONIERA MODULARE IN PMMA/
MODULAR CEILING LAMP IN PMMA**
DESIGN MAURO MARZOLLO, 2008



57

MISSTRASS_PL50 C
PLAFONIERA MODULARE IN PMMA/
MODULAR CEILING LAMP IN PMMA

DESIGN MAURO MARZOLLO, 2008

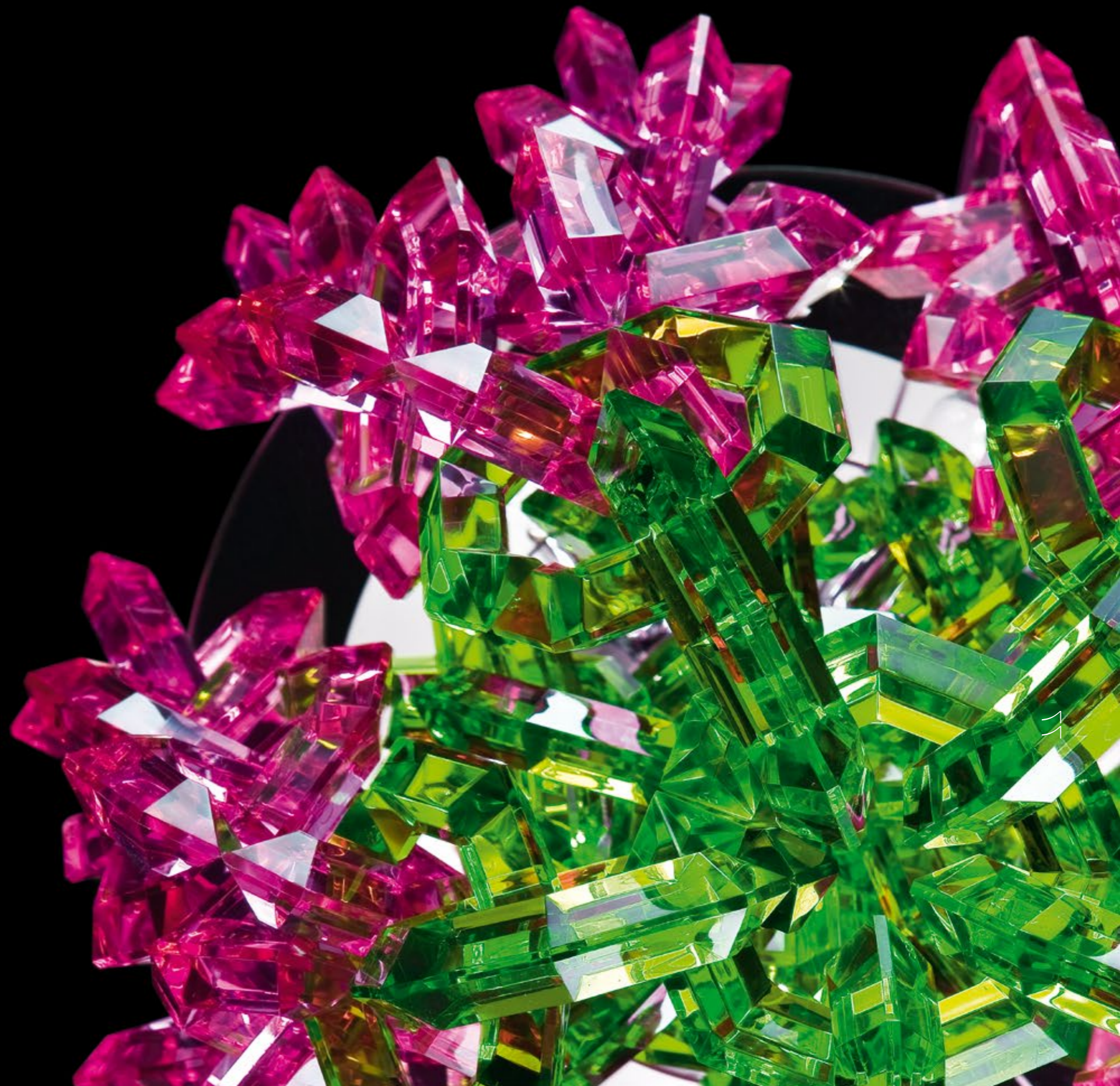





MISSTRASS_PL100
PLAFONIERA MODULARE IN PMMA/
MODULAR CEILING LAMP IN PMMA

DESIGN MAURO MARZOLLO, 2008





MISSTRASS _ SPHERE 70
SOSPENSIONE MODULARE IN PMMA /
MODULAR SUSPENDED LAMP IN PMMA

DESIGN MAURO MARZOLLO, 2011









MISSTRASS_50
SOSPENSIONE MODULARE IN PMMA/
MODULAR SUSPENDED LAMP IN PMMA

DESIGN MAURO MARZOLLO, 2008







04

FAÇON DE VENISE MISSTRASS

MISSTRASS AP
APPLIQUE MODULARE IN PMMA/
MODULAR WALL LAMP IN PMMA
DESIGN MAURO MARZOLLO, 2008



05

Diffusore realizzato con elementi componibili in pmma nei colori: carbone, cristallo, miele, ciliegia, lampone, lime e acquamarine. Montatura inox lucido.

Diffuser comprising modular elements in PMMA in the following colours: coal, crystal, honey, cherry, raspberry, lime and aquamarine. Fixture in polished stainless steel.

- 40W E14
- 7W E14
- 100W E27
- 100W E27 HALOPAR 30
- 23W E27
- 20W E27
- 60W E14
- 60W E27
- 15W E27
- 30W E27 FLUOR
- 75W E27 INC

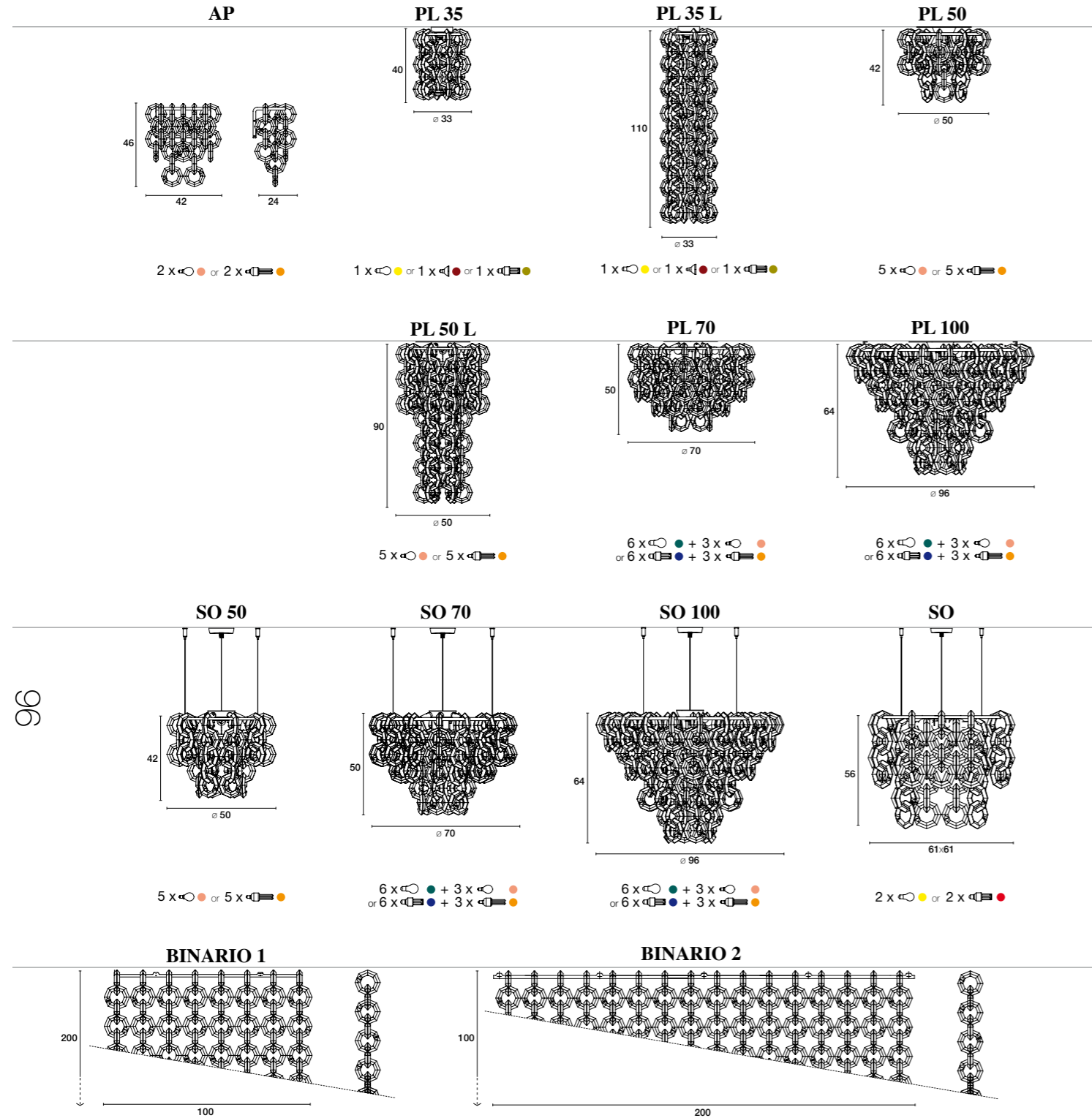

MISSTRASS
table of contents

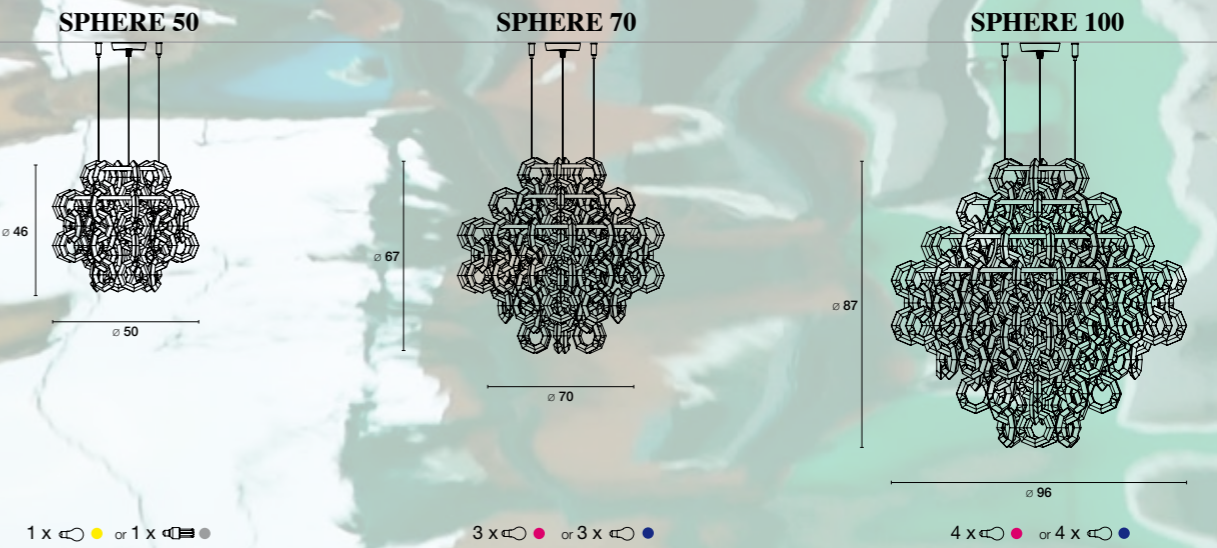



ARCHITECTURAL LIGHTING ELEMENTS

Contrasting light and shade, reflected landscapes, colours and global voices and silence in the fog: the most genuine atmospheres of the lagoon city inspire the contemporary path taken by Façon de Venise.

ARCHITETTURE
DI LUCE

ARCHITETTURE
DI LUCE

Contrasti di luci ed ombre, paesaggi di riflessi e mosaici dai mille colori, voci dal mondo e silenzi nella nebbia: dalle atmosfere più autentiche della città lagunare traggono ispirazione forme e colori che animano il percorso contemporaneo di Façon de Venise.



AQUA design brian rasmussen

AQUA _ SO L
COMPOSIZIONE MODULARE
DI PARALUMI IN TESSUTO/
MODULAR ARRANGEMENT
OF LAMPSHADES IN FABRIC

DESIGN BRIAN RASMUSSEN, 2010



"BILBO" LOUNGE BAR _ THE GARDENS OF THE BIENNALE / VENICE _ 11,30 PM





AQUA _ SO 15L
COMPOSIZIONE MODULARE
DI PARALUMI IN TESSUTO/
MODULAR ARRANGEMENT OF LAMPSHADES IN FABRIC

DESIGN BRIAN RASMUSSEN, 2010



AQUA _ SO 9L
COMPOSIZIONE MODULARE DI PARALUMI IN TESSUTO /
MODULAR ARRANGEMENT OF LAMPSHADES IN FABRIC

DESIGN BRIAN RASMUSSEN, 2010

PRIVATE HOUSE _ S. ELENA GARDENS / VENICE _ 10.25 AM





"CENTRALE" LOUNGE BAR _ S. MARCO / VENICE _ 11.40 AM



114
FAÇON DE VENISE AQUA

AQUA MAXI _ SO 1L UP
ELEMENTO MODULARE CON PARALUME IN TESSUTO /
MODULAR ELEMENT WITH LAMPSHADES IN FABRIC

DESIGN BRIAN RASMUSSEN, 2012



115

AQUA MAXI _ SO 5L
COMPOSIZIONE MODULARE DI PARALUMI IN TESSUTO /
MODULAR ARRANGEMENT OF LAMPSHADES IN FABRIC

DESIGN BRIAN RASMUSSEN, 2012

AQUA _ SO 20 CUSTOM
COMPOSIZIONE MODULARE DI PARALUMI IN TESSUTO/
MODULAR ARRANGEMENT OF LAMPSHADES IN FABRIC

DESIGN BRIAN RASMUSSEN, 2010

PRIVATE HOUSE _ BURANO / VENICE _ 2.10 PM



AQUA_SO 12 CUSTOM
**COMPOSIZIONE MODULARE DI PARALUMI IN TESSUTO/
MODULAR ARRANGEMENT OF LAMPSHADES IN FABRIC**

DESIGN BRIAN RASMUSSEN, 2013





124

FAÇON DE VENISE AQUA

AQUA _ TA UP + MAXI TA UP
LAMPADA DA TAVOLO CON PARALUME IN TESSUTO /
TABLE LAMP WITH LAMPSHADES IN FABRIC

DESIGN BRIAN RASMUSSEN, 2013



152



AQUA_TR
LAMPADA DA TERRA CON PARALUME IN TESSUTO/
FLOOR LAMP WITH LAMP SHADES IN FABRIC

DESIGN BRIAN RASMUSSEN, 2013



AQUA TR
**LAMPADA DA TERRA CON PARALUME IN TESSUTO/
FLOOR LAMP WITH LAMPSHADES IN FABRIC**

DESIGN BRIAN RASMUSSEN, 2012





AQUA SPHERE 160 MIX 18L
SOSPENSIONE MODULARE
DI PARALUMI IN TESSUTO/
MODULAR SUSPENDED LAMP
OF LAMPSHADES IN FABRIC

DESIGN BRIAN RASMUSSEN, 2012





AQUA _ SPHERE 160 MIX 181
SOSPENSIONE MODULARE DI PARALUMI IN TESSUTO /
MODULAR SUSPENDED LAMP OF LAMPSHADES IN FABRIC

DESIGN BRIAN RASMUSSEN, 2012



AQUA SPHERE 80 18L
**SOSPENSIONE MODULARE DI PARALUMI IN TESSUTO/
MODULAR SUSPENDED LAMP OF LAMPSHADES IN FABRIC**

DESIGN BRIAN RASMUSSEN, 2012



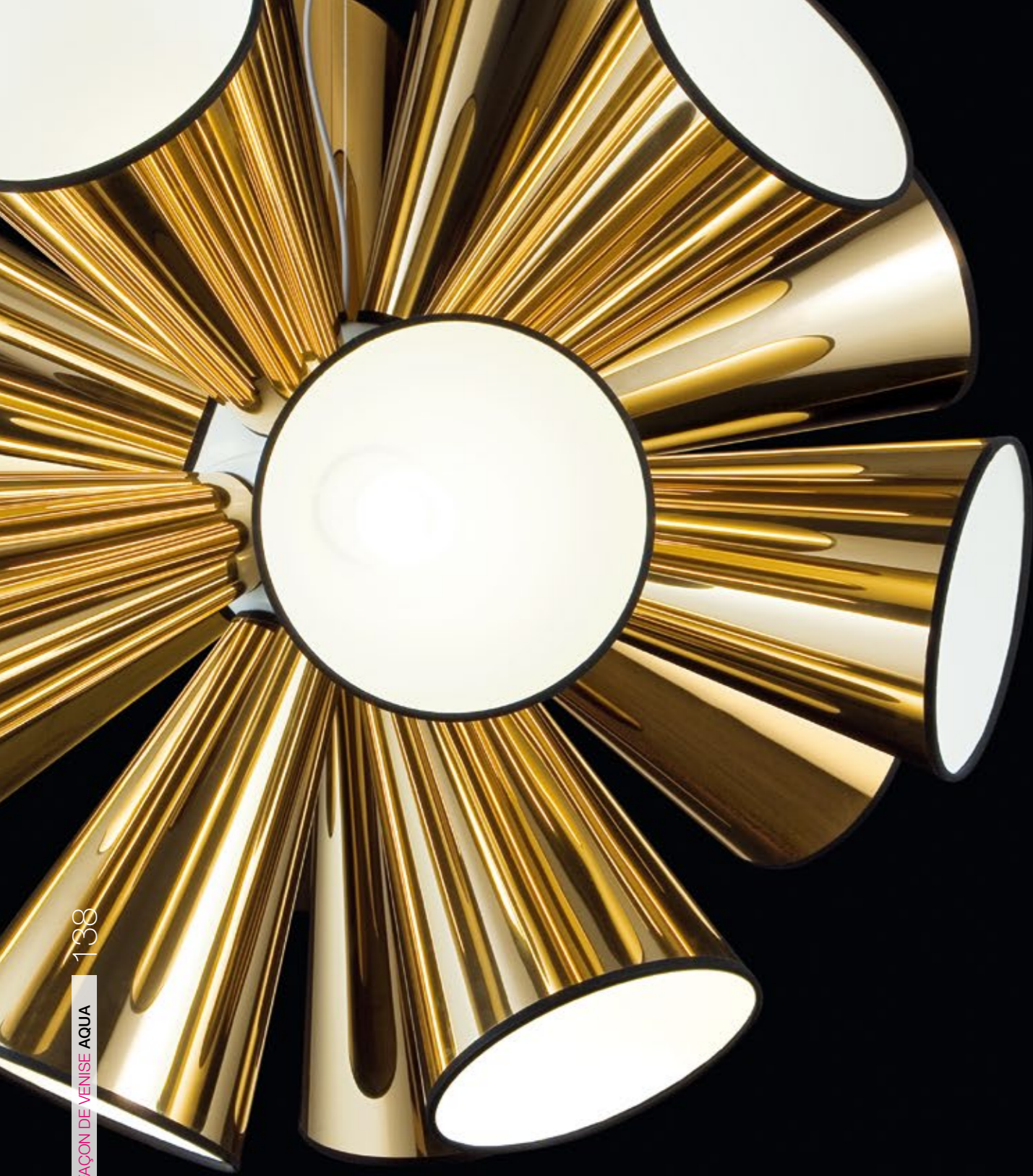

138

FAÇON DE VENISE AQUA

AQUA _ SPHERE 80 18L
SOSPENSIONE MODULARE DI PARALUMI IN PVC ORO E ARGENTO /
MODULAR SUSPENDED LAMP OF LAMPSHADES GOLD AND SILVER PVC

DESIGN BRIAN RASMUSSEN, 2013



139



AQUA _AP
LAMPADA DA PARETE
CON PARALUMI IN TESSUTO/
WALL LAMP WITH LAMPSHADES IN FABRIC

DESIGN BRIAN RASMUSSEN, 2012





AP

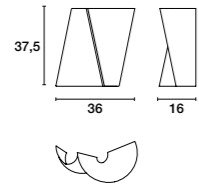

2 x or 2 x

SO 1L DOWN

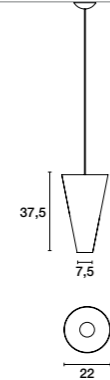

1 x or 1 x

SO 1L UP

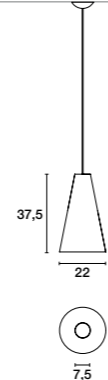

1 x or 1 x

TA UP

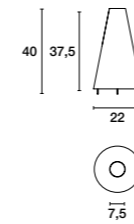

1 x or 1 x

MAXI TA UP

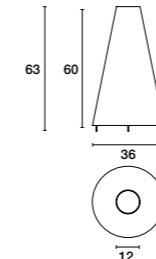

1 x or 1 x

TR

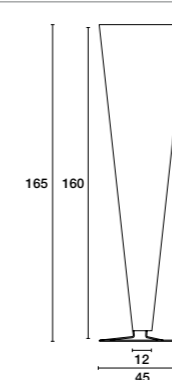

2 x or 2 x

MAXI SO 1L UP

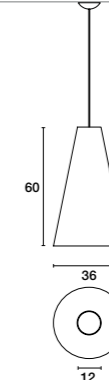

1 x or 1 x

MAXI SO 1L DOWN

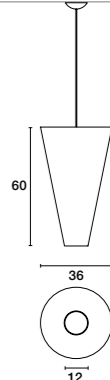

1 x or 1 x

SO 3L

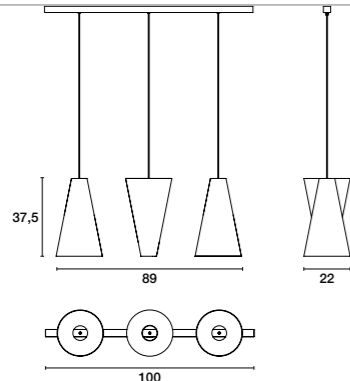

3 x or 3 x

SO 5L

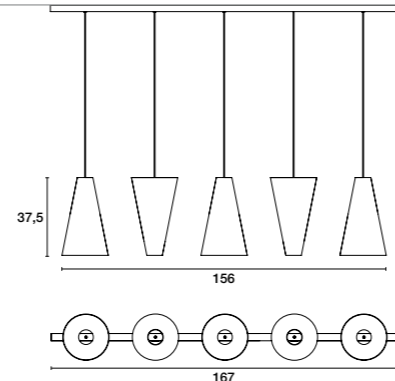

5 x or 5 x

MAXI SO 3L

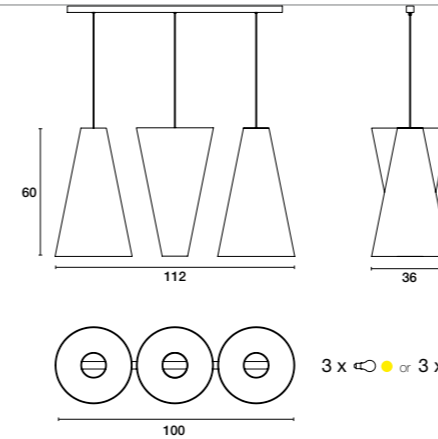

3 x or 3 x

MAX SO 5L

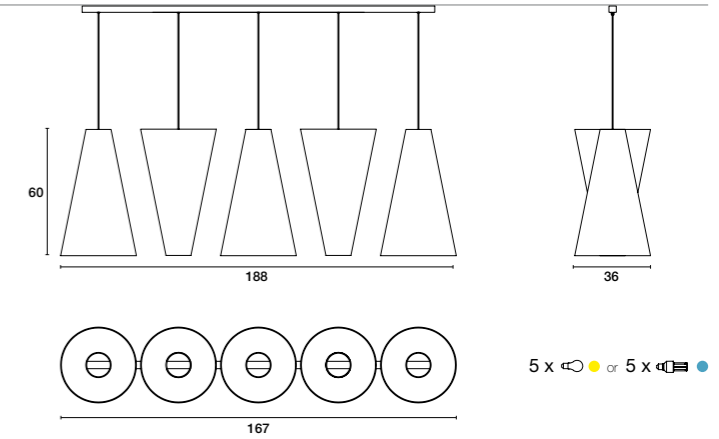

5 x or 5 x

SO 9L

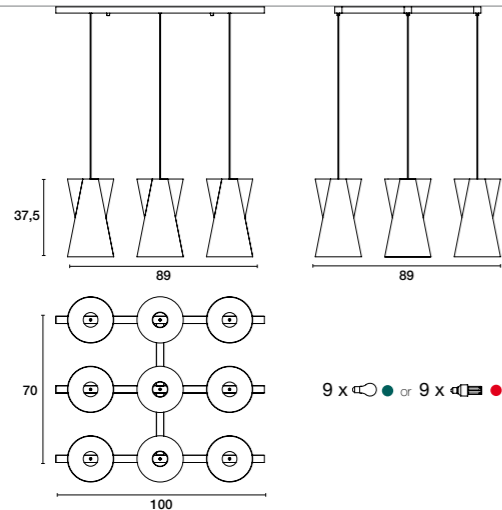

9 x or 9 x

SO 15L

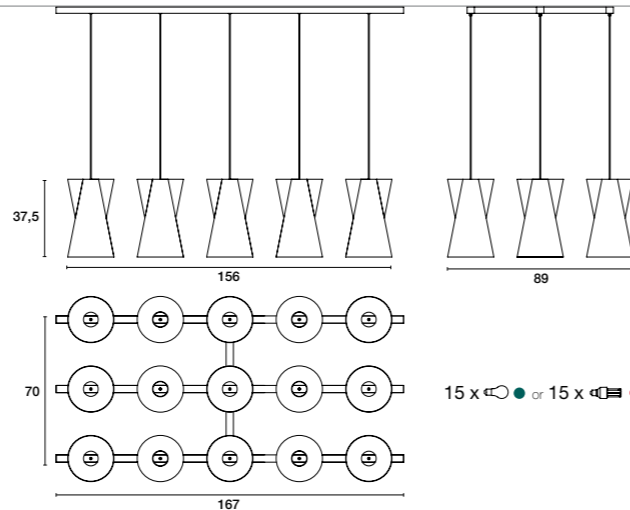

15 x or 15 x

MAXI SO 9L

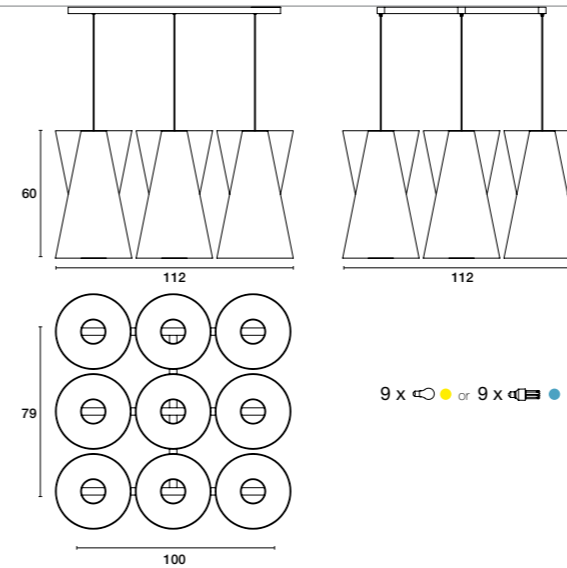

9 x or 9 x

MAXI SO 15L

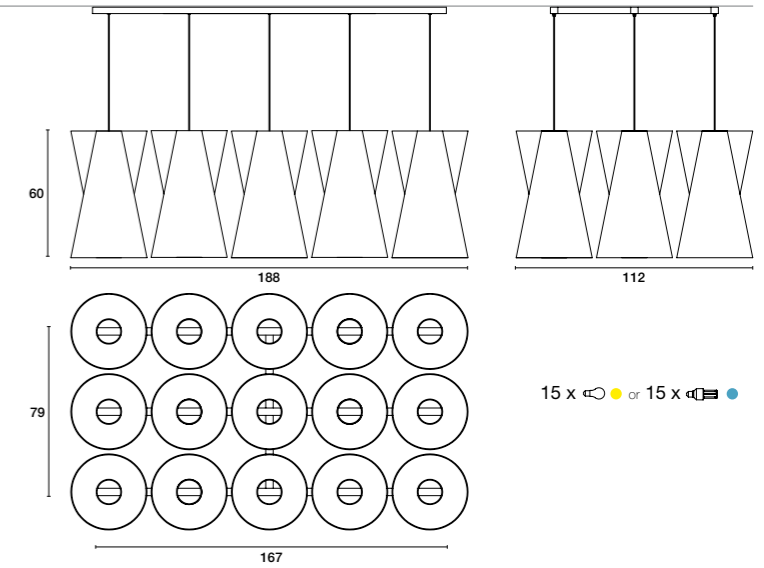

15 x or 15 x

Sistema modulare composto da paralumi diffusori nei colori Light4fabrics (vedi www.light4.it).
Montatura in metallo bianco.

Modular system composed of lampshades available in Light4fabrics colours (see www.light4.it).
Fixture in white metal.

- 60W E27
- 20W E27
- 30W E27
- 100W E27
- 15W E27

SPHERE 50 9L

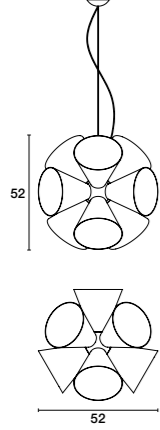

9 x

SPHERE 60 9L

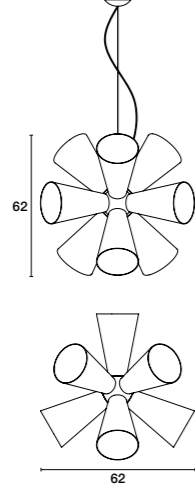

9 x

SPHERE 70 9L

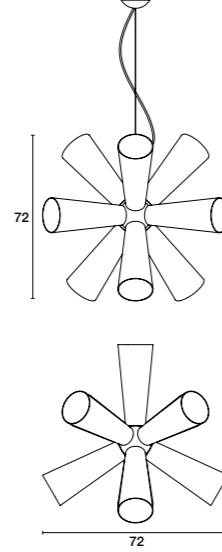

9 x

SPHERE 70 mix 9L

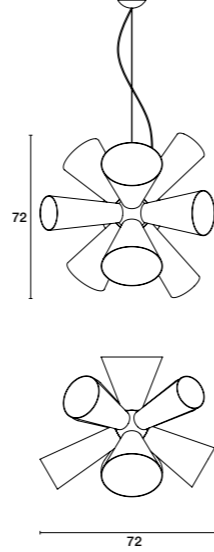

9 x

SPHERE 60 18L

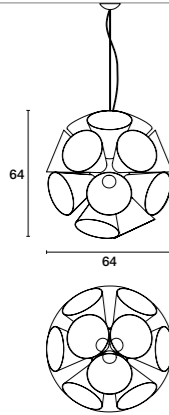

18 x

SPHERE 80 18L

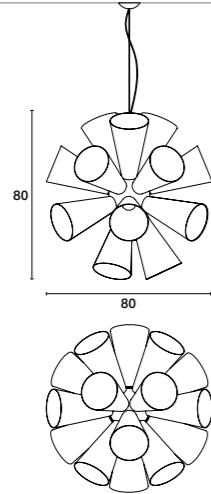

18 x

SPHERE 100 18L

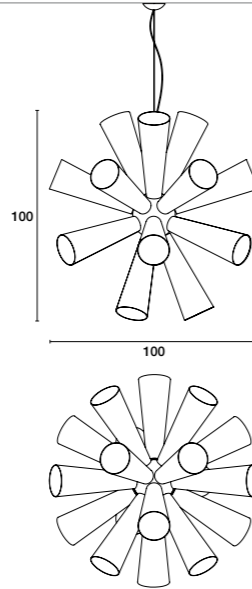

18 x

SPHERE 100 mix 18L

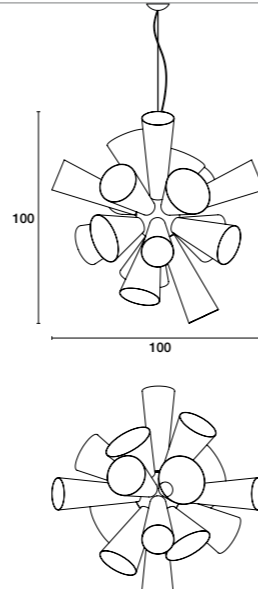

18 x

SPHERE 120 18L

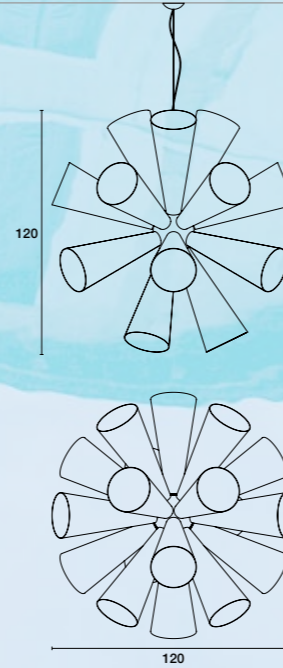

18 x

SPHERE 160 18L

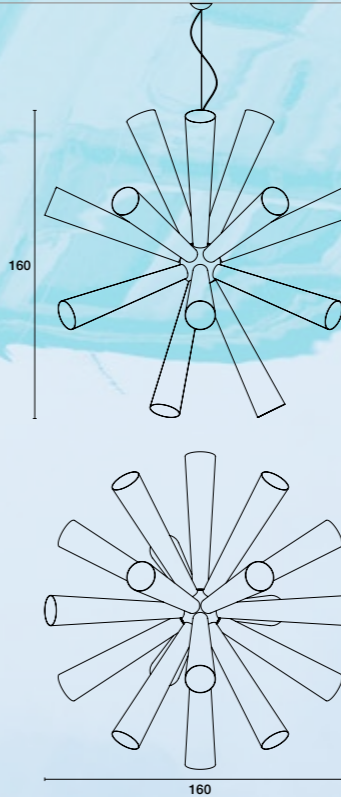

18 x

SPHERE 160 mix 18L

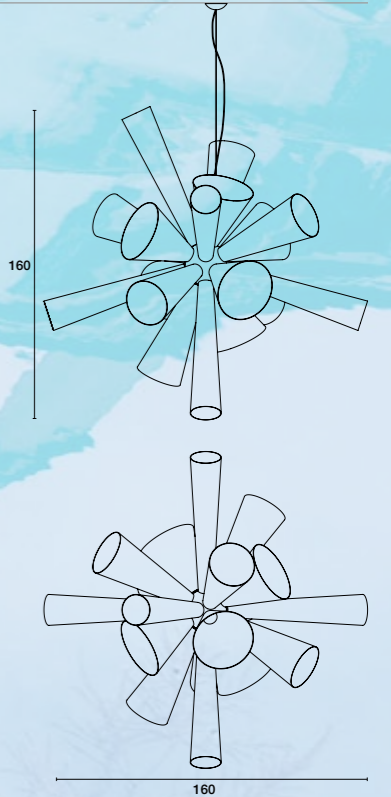

18 x



LIMELIGHT

design lorenzo bertocco

LIMELIGHT_28.6
LAMPADARIO DESTRUTTURATO IN CRISTALLO/
DECONSTRUCTED CHANDELIER IN CRYSTAL GLASS

DESIGN LORENZO BERTOCCO, 1999



LIMELIGHT_28.6
**LAMPADARIO DESTRUTTURATO IN CRISTALLO/
DECONSTRUCTED CHANDELIER IN CRYSTAL GLASS**

DESIGN LORENZO BERTOCCO, 1999





LIMELIGHT_12.4
**LAMPADARIO DESTRUTTURATO IN CRISTALLO/
DECONSTRUCTED CHANDELIER IN CRYSTAL GLASS**

DESIGN LORENZO BERTOCCO, 1999





158

FAÇON DE VENISE LIMELIGHT

021

LIMELIGHT_11
**FARETTO CON ELEMENTI IN CRISTALLO/
SPOTLIGHT WITH ELEMENTS IN CRYSTAL GLASS**
DESIGN LORENZO BERTOCCO, 1999









Thanks to its modular nature, complex installations can be created with the Limelight collection; true architectural lighting with great visual appeal.

SECTIONAL & MODULAR COMPONIBILE & MODULARE

La collezione Limelight, in quanto modulare, permette la realizzazione di installazioni complesse, vere e proprie architetture di luce dal grande impatto visivo.

LIMELIGHT
**COMPOSIZIONE DESTRUTTURATO IN CRISTALLO/
DECONSTRUCTED COMPOSITION IN CRYSTAL GLASS**

DESIGN LORENZO BERTOCCO, 2012







LIMELIGHT
design lorenzo bertocco

Diffusore in vetro cristallo
trasparente, nero e trasparente.
Montatura in inox lucido.

Diffuser in transparent,
black/transparent or white/transparent
crystal glass.
Fixture in polished stainless steel.

50 W GU10  ●
50 W G53 QR111  ●

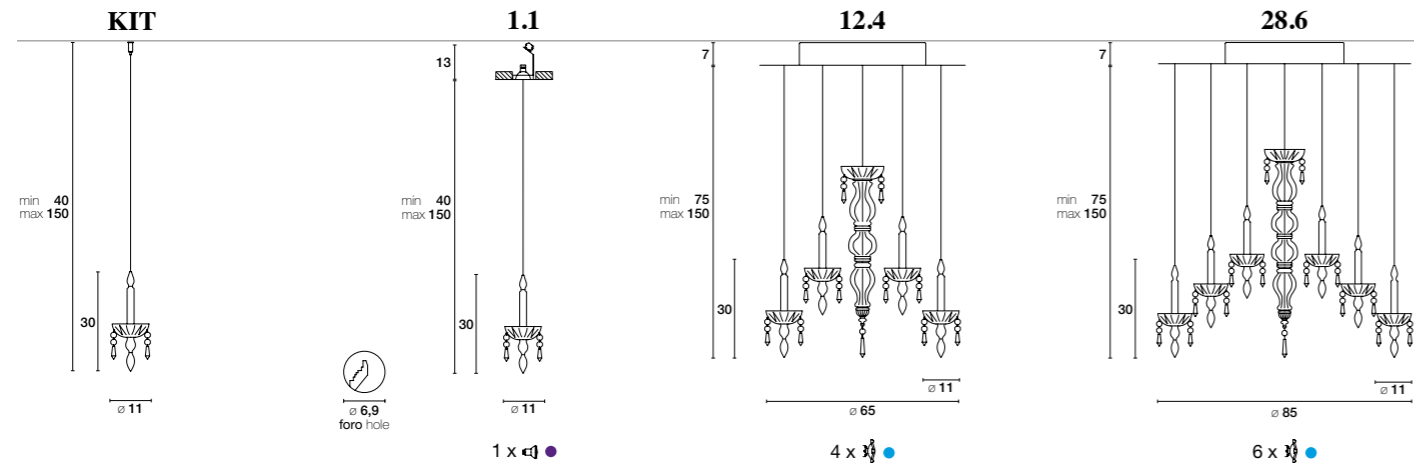

LIMELIGHT
table of contents



TRADITIONS AND CONTEMPORARY STYLE

Natural elements and man's creations have always existed in Venice:
an ideal place for designing and making original lighting elements.
But everyday reality requires research.
Façon de Venise contaminates Venetian traditions, discovers new paths and looks beyond the horizon,
with a desire to excite and seize the style of our times.

CONTEMPORANEO
E STORIE

STORIE E CONTEMPORANEO

A Venezia da sempre si incontrano elementi della natura e idee dell'uomo:
un luogo ideale per disegnare e costruire forme di luce originali.
Ma la realtà odierna ci impone la ricerca.
Façon de Venise contamina memorie veneziane, scopre nuove vie
e volge lo sguardo oltre l'orizzonte,
con il desiderio di emozionare e catturare il gusto del nostro tempo.



DRILL

design cambi scatena turini

**DRILL AP/PL 80,
PLAFONIERA IN GESSO DECORATO/
CEILING LAMP IN ORNAMENTED PLASTER**

DESIGN CAMBI SCATENA TURINI, 2013





180
FAÇON DE VENISE DRILL

**DRILL AP/PL 40,
APPLIQUE IN GESSO DECORATO/
WALL LAMP IN ORNAMENTED PLASTER**

DESIGN CAMBI SCATENA TURINI, 2013

181

**DRILL_ SO 80,
SOSPENSIONE IN GESSO DECORATO/
SUSPENDED LAMP IN ORNAMENTED PLASTER**

DESIGN CAMBI SCATENA TURINI, 2013





184

FAÇON DE VENISE DRILL

**DRILL_SO 80,
SOSPENSIONE IN GESSO DECORATO/
SUSPENDED LAMP IN ORNAMENTED PLASTER**

DESIGN CAMBI SCATENA TURINI, 2013

181

Lampada in gesso decorato.
Lamp in ornamented plaster.

- 60W G9
- 55W 2GX13
- 17.5W LED 220-240V 3000°K
- 13W LED 220-240V 3000°K

AP/PL 40

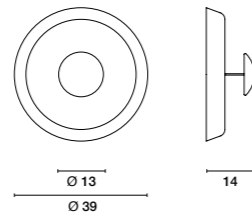

1 x or 1 x LED

AP/PL 80

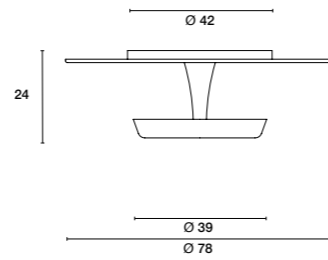

1 x or 3 x LED

KIT SO 80 PLUS

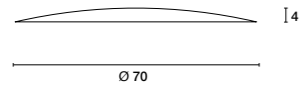

diffusore metacrilato monosatinato
diffuser in satinated methacrylate

SO 80

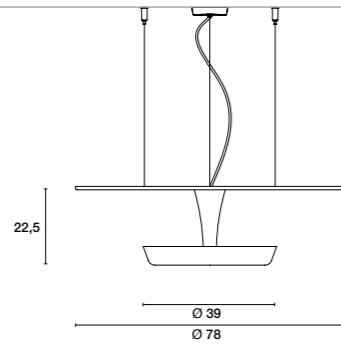

1 x or 3 x LED

SO 80 PLUS

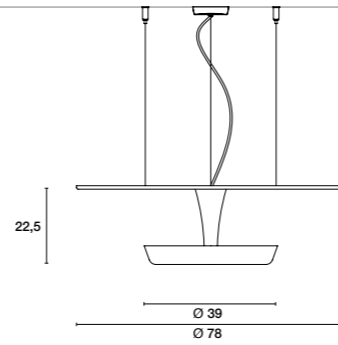

1 x or 3 x LED + 2 x LED



DRILL
table of contents



CHANDELIER

design peter lunetta

MERIPRS
SUZANNE
EMY
REBECCA
MAMO
BARBARA
NICOLE
MARIANGE
VANESSA
CHRISTINE



**MERIPIRS,
LAMPADARIO IN GOMMA SPECIALE COLORATA/
LAMP IN SPECIAL COLOURED RUBBER**

DESIGN PETER LUNETTA, 2005

**MERIPIRS,
LAMPADARIO IN GOMMA SPECIALE COLORATA/
LAMP IN SPECIAL COLOURED RUBBER**

DESIGN PETER LUNETTA, 2005

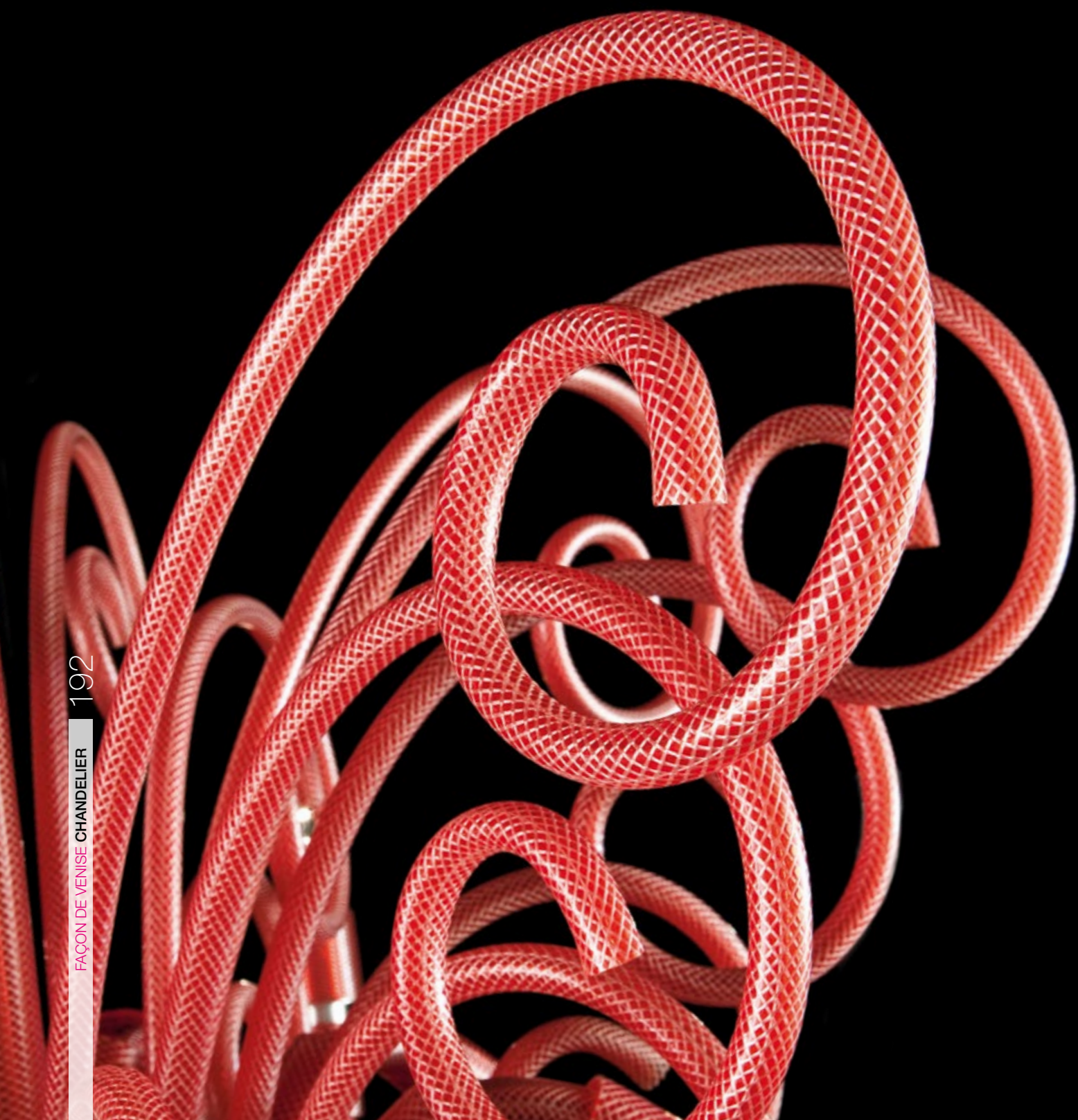

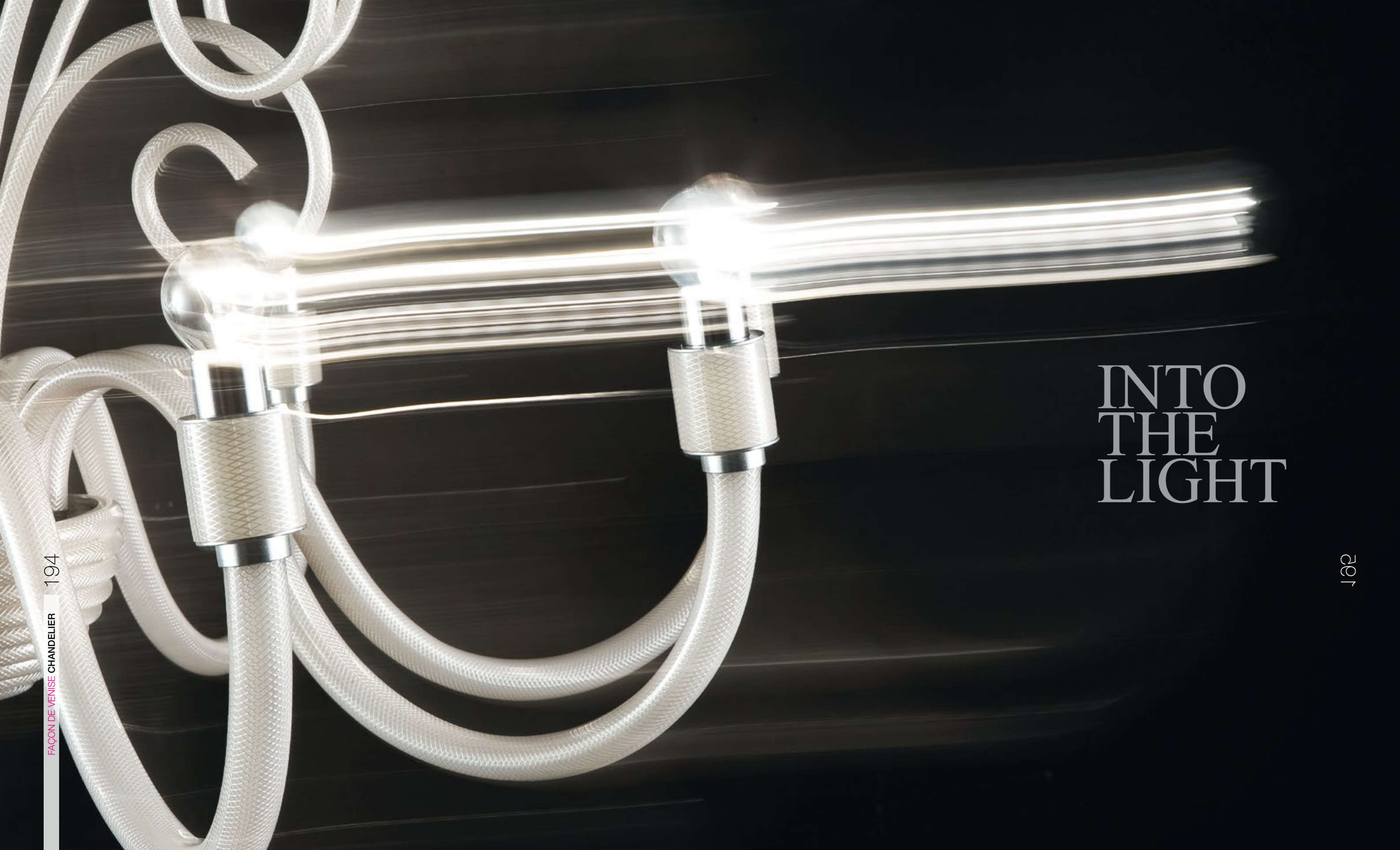

194

FAÇON DE VENISE CHANDELIER

INTO THE LIGHT

194

**SUZANNE,
LAMPADARIO IN GOMMA SPECIALE COLORATA/
LAMP IN SPECIAL COLOURED RUBBER**

DESIGN PETER LUNETTA, 2005



198

FAÇON DE VENISE CHANDELIER

**SUZANNE,
LAMPADARIO IN GOMMA SPECIALE COLORATA/
LAMP IN SPECIAL COLOURED RUBBER**

DESIGN PETER LUNETTA, 2005



198

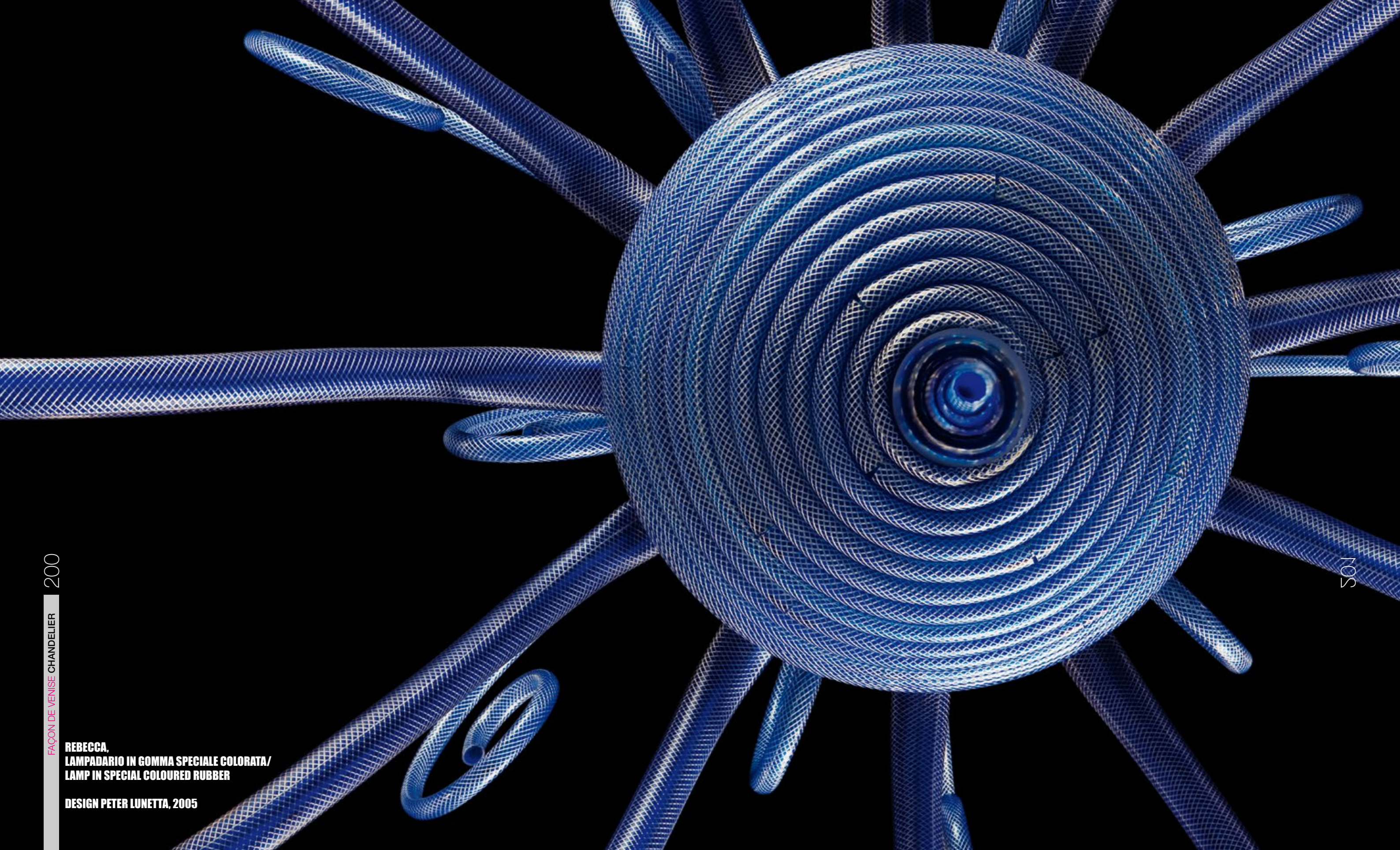

**REBECCA,
LAMPADARIO IN GOMMA SPECIALE COLORATA/
LAMP IN SPECIAL COLOURED RUBBER**

DESIGN PETER LUNETTA, 2005



BARBARA,
LAMPADARIO IN GOMMA SPECIALE COLORATA/
LAMP IN SPECIAL COLOURED RUBBER

DESIGN PETER LUNETTA, 2005



**BARBARA,
LAMPADARIO IN GOMMA SPECIALE COLORATA/
LAMP IN SPECIAL COLOURED RUBBER**

DESIGN PETER LUNETTA, 2005



FAÇON DE VENISE CHANDELIER 206

"CAFFÈ FLORIAN" _ S. MARCO SQUARE / VENICE _ 11.00 AM

**CHRISTINE,
APPLIQUE IN GOMMA SPECIALE COLORATA/
WALL LAMP IN SPECIAL COLOURED RUBBER**

DESIGN PETER LUNETTA, 2005



205

**SUZANNE,
LAMPADARIO IN GOMMA SPECIALE COLORATA
CON KIT PER ESTERNO IP44/
LAMP IN SPECIAL COLOURED RUBBER WITH KIT FOR OUTDOOR IP44**

DESIGN PETER LUNETTA, 2005







CHANDELIER

design peter lunetta

Lampadario in gomma nei colori:
bianco, ambra, nero, rosso fuoco, fuxia,
blu, verde acido.
Montatura in metallo bianco.

Rubber lamp in the following colours:
white, amber, black, flame red, fuchsia,
blue and acid green.
Fixture in white metal.

60W E14  
11W E14  



CHANDELIER

table of contents

IP

IP 44



CHRISTINE 2P

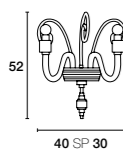

2 x  or 2 x 

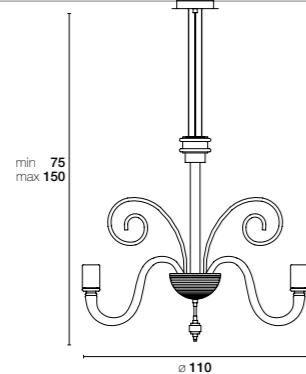

REBECCA 12L



12 x  or 12 x 

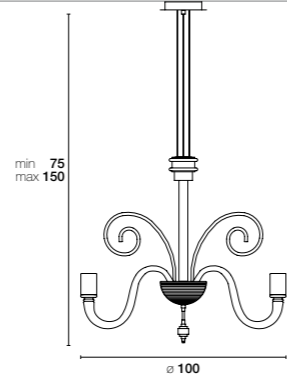

MERIPIRS 8L

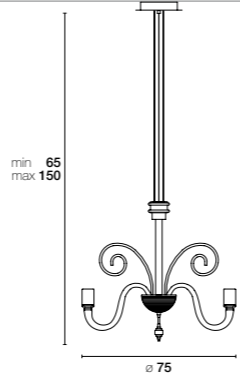

8 x  or 8 x 

EMY 8L



8 x  or 8 x 

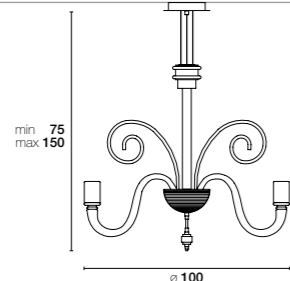

SUZANNE 8L

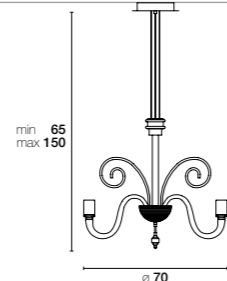

8 x  or 8 x 

BARBARA 6L



6 x  or 6 x 

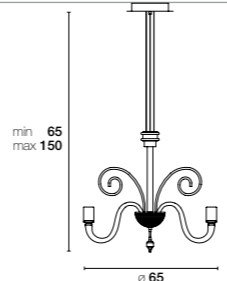

NICOLE 3L



3 x  or 3 x 

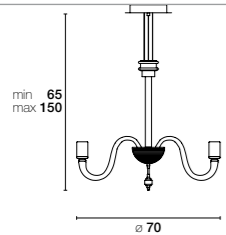

MARIANGE 8L

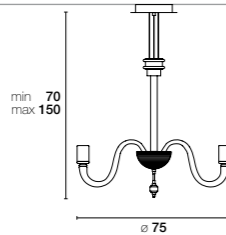

8 x  or 8 x 

VANESSA 6L



6 x  or 6 x 

MAMO 6L

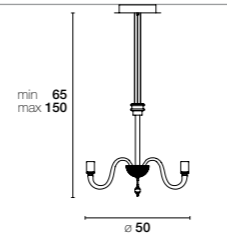

3 x  or 3 x 

MAMO 3L

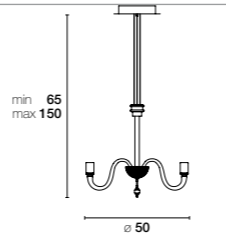

3 x  or 3 x 

BRICK
design brian rasmussen

212

213

**BRICK COMPO 2 SQ 60,
COMPOSIZIONE MODULARE IN TESSUTO /
MODULAR COMPOSITION IN FABRIC**

DESIGN BRIAN RASMUSSEN, 2013







**BRICK COMPO MAXI,
COMPOSIZIONE SPECIALE IN TESSUTO/
SPECIAL COMPOSITION IN FABRIC**

DESIGN BRIAN RASMUSSEN, 2013





**BRICK _ AP/PL SQ 60,
SEQUENZA DI MONTAGGIO/
ASSEMBLY SEQUENCE**

DESIGN BRIAN RASMUSSEN, 2013



Brick in the Wall



**BRICK _ COMPO 4 AP/PL 75,
COMPOSIZIONE MODULARE IN TESSUTO/
MODULAR COMPOSITION IN FABRIC**

DESIGN BRIAN RASMUSSEN, 2013

**BRICK _ COMPO 2 AP/PL 75,
COMPOSIZIONE MODULARE IN TESSUTO/
MODULAR COMPOSITION IN FABRIC**

DESIGN BRIAN RASMUSSEN, 2013



230

FAÇON DE VENISE BRICK

**BRICK _ 2 AP/PL 150,
COMPOSIZIONE MODULARE IN TESSUTO/
MODULAR COMPOSITION IN FABRIC**

DESIGN BRIAN RASMUSSEN, 2013



231

**BRICK _ 2 AP/PL 45,
COMPOSIZIONE MODULARE IN TESSUTO/
MODULAR COMPOSITION IN FABRIC**

DESIGN BRIAN RASMUSSEN, 2013

BRICK AP/PL SQ 60.
COMPOSIZIONE MODULARE IN PVC ORO /
MODULAR COMPOSITION IN GOLD PVC

DESIGN BRIAN RASMUSSEN, 2013



Lampada modulare. Montatura metallo verniciato bianco. Diffusore in metacrilato bianco con elementi decorativi in tessuto Light4fabrics (vedi www.light4.it).

Modular lamp. White painted metal frame. Diffuser in white methacrylate with decorative elements in fabric available in Light4fabrics colours (see www.light4.it).

- 22W 2GX13 ●
- 24W G5 ●
- 55W 2GX13 ●
- 39W G5 ●

AP/PL 45

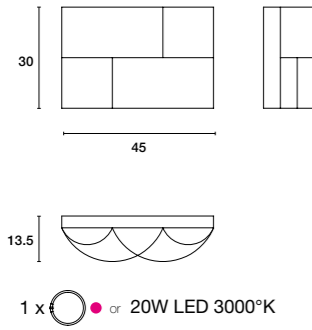

AP/PL 75

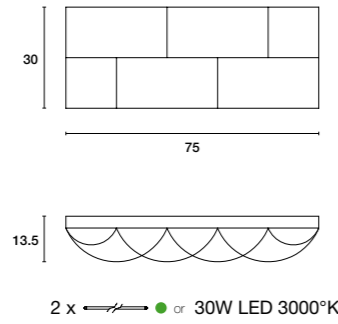

AP/PL SQ 45

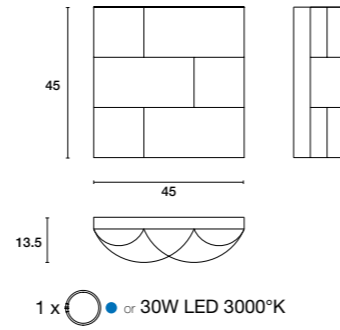

AP/PL SQ 60

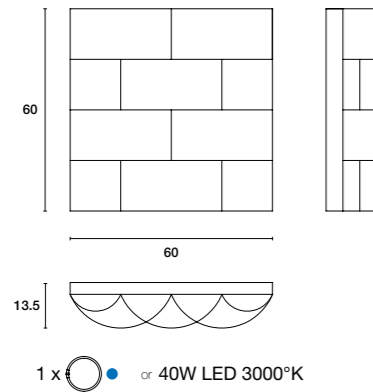

AP/PL 150

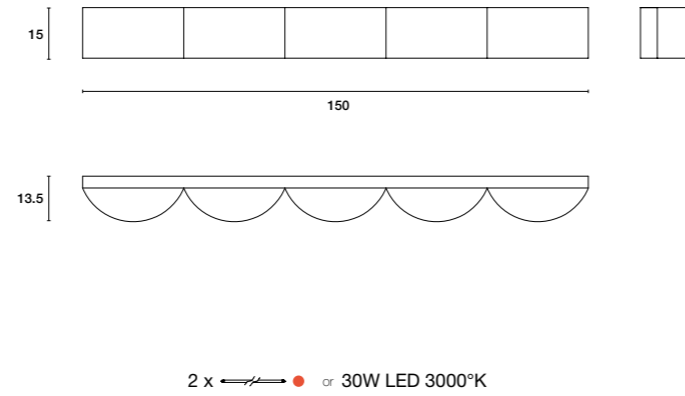

COMPO 4 AP/PL 75

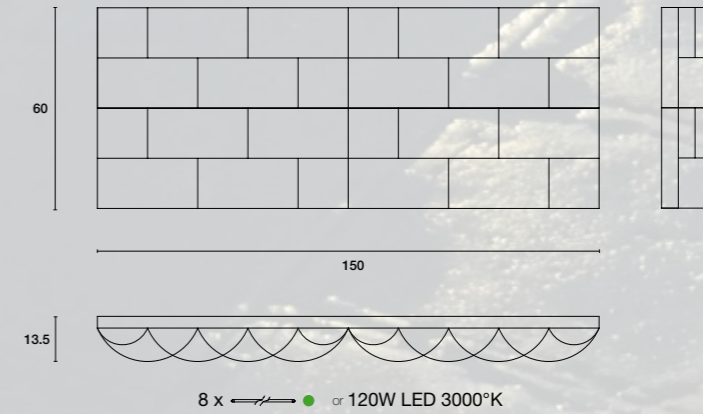

COMPO 2 AP/PL SQ 60

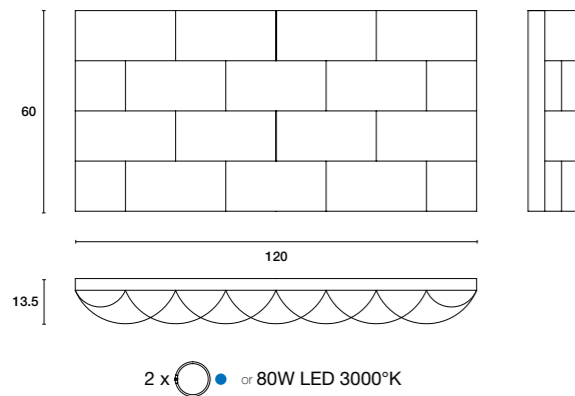

COMPO 2 AP/PL 75

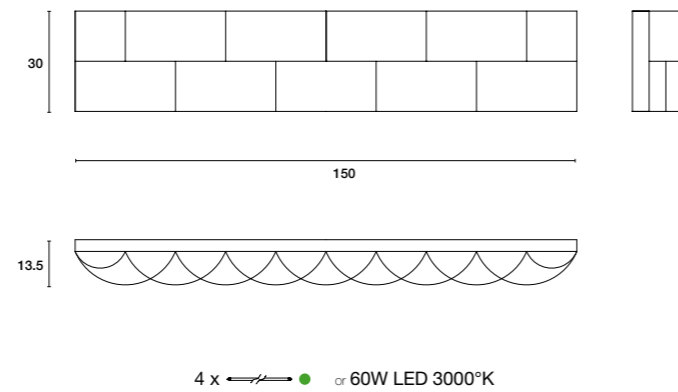

COMPO MAXI

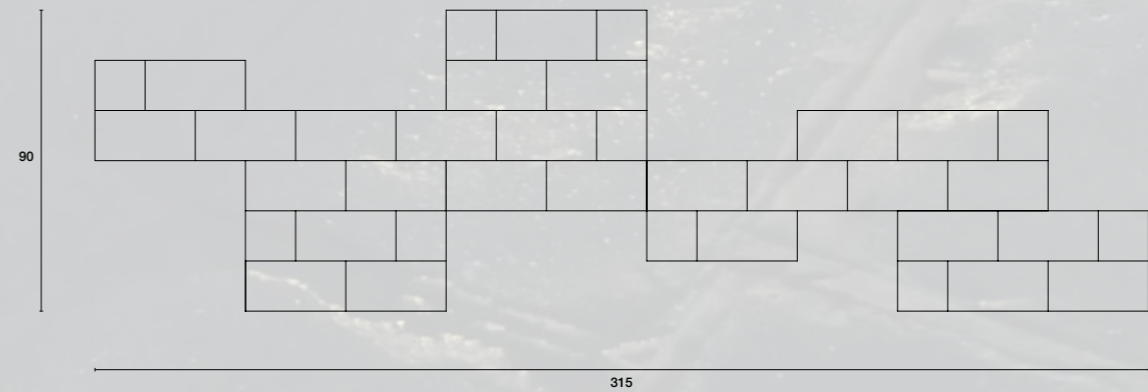



NOT ONLY DESIGN

Venice is inspiration, colours and tradition.
Façon de Venise is modern, original and exuberant:
new sources of light are inspired by the bustling places of a timeless city.

E NON SOLO
DESIGN

DESIGN
E NON SOLO

Venezia è ispirazione, colori e storia.
Façon de Venise è giovane, originale, esuberante:
nuove esperienze di luce nascono dall'incontro con i luoghi più vivi
di una città senza tempo.



BLOOM

design brian rasmussen



**BLOOM _ SO 120,
SOSPENSIONE IN METALLO TORNITO E CURVATO/
SUSPENDED LAMP IN CURVED LATHE-TURNED METAL**

DESIGN BRIAN RASMUSSEN, 2009





INTO
THE
LIGHT

**BLOOM SO 120,
SOSPENSIONE IN METALLO TORNITO E CURVATO/
SUSPENDED LAMP IN CURVED LATHE-TURNED METAL**

DESIGN BRIAN RASMUSSEN, 2009



**BLOOM _ PL 120,
PLAFONIERA IN METALLO TORNITO E CURVATO/
CEILING LAMP IN CURVED LATHE-TURNED METAL**

DESIGN BRIAN RASMUSSEN, 2009











**BLOOM_ SO 80,
SOSPENSIONE IN METALLO TORNITO E CURVATO/
SUSPENDED LAMP IN CURVED LATHE-TURNED METAL**

DESIGN BRIAN RASMUSSEN, 2009

Diffusore in metallo bianco o bianco / foglia oro.
Montatura in metallo bianco o foglia oro.

Diffuser in white metal or white / gold leaf.
Fixture in white metal or gold leaf.

100W E27  
20W E27  
60W E27  

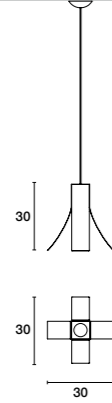

1.30

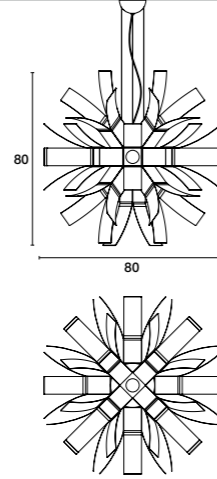

1 x   or 1 x  

SO 80



17 x   or 17 x  



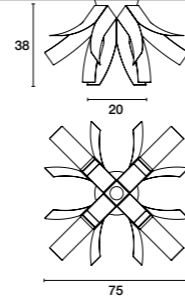

PL 80

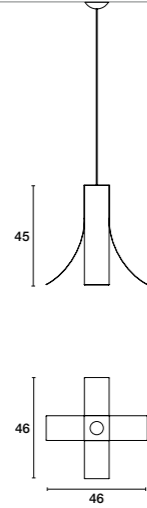

5 x   or 5 x  

1.45



1 x   or 1 x  

SO 120

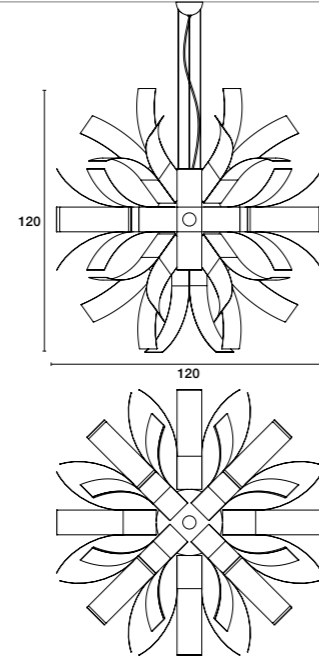

17 x   or 17 x  

PL 120

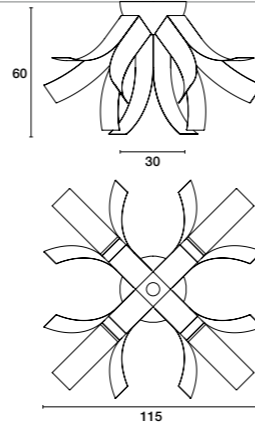

5 x   or 5 x  

SINFONIA
design
massimo
tonetto



**SINFONIA AP 101,
LAMPADA DA PARETE IN METACRILATO TRASPARENTE CON SERIGRAFIA BIANCA/
WALL LAMP IN TRANSPARENT METHACRYLATE WITH WHITE DECORATION**

DESIGN MASSIMO TONETTO, 2005

"GELLIUS" RESTAURANT A FEW MILES FROM VENICE _ 2.00 PM



258

FAÇON DE VENISE SINFONIA



259

**SINFONIA _ SO 6L,
SOSPENSIONE IN METACRILATO TRASPARENTE CON SERIGRAFIA NERA/
SUSPENDED LAMP IN TRANSPARENT METHACRYLATE WITH BLACK DECORATION**

DESIGN MASSIMO TONETTO, 2005







**SINFONIA _SO 6,
SOSPENSIONE IN METACRILATO TRASPARENTE CON SERIGRAFIA ROSSA/
SUSPENDED LAMP IN TRANSPARENT METHACRYLATE WITH RED DECORATION**

DESIGN MASSIMO TONETTO, 2005



SINFONIA
design massimo tonetto

Lampadario a luce diffusa. Chandelier providing diffused light.
Struttura in metallo cromato. Metal structure and components
in chrome finish. Methacrylate
Diffusore in metacrilato
trasparente con serigrafia
colorata bianca, rossa o nera.
diffuser transparent shade with
white, red or black decoration.

20W G4  ●
10W G4  ●
4W LED G4  ●

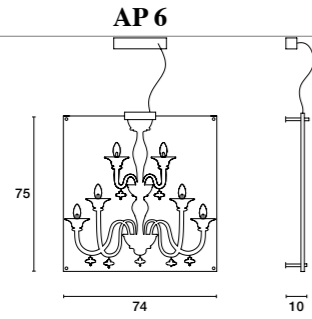

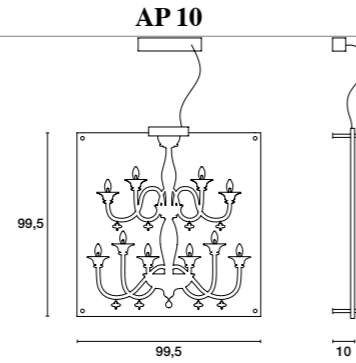

6 x  ● or 6 x  LED ●

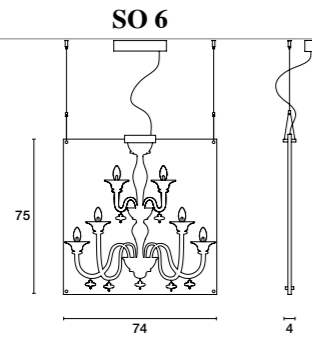

10 x  ● or 10 x  LED ●



6 x  ● or 6 x  LED ●

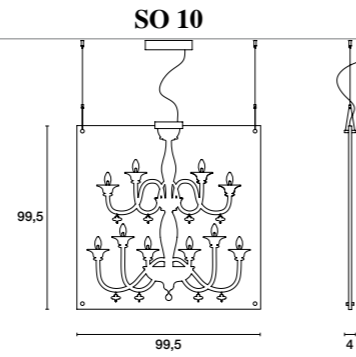

10 x  ● or 10 x  LED ●



SINFONIA
table of contents

LUCI IN SCENA

FOCUSING ON LIGHTS

Discovering paths, illuminating interiors,
mixing and interpreting traditions:
Façon de Venise brings light and character to any space.
Contamination, expression and composition:
just close your eyes for a new attractive setting.

LUCI IN SCENA

Percorsi da scoprire, ambienti da illuminare,
intrecci e rappresentazioni di storie:
Façon de Venise anima di luce e personalità ogni spazio.

Contaminazione, dialogo, composizione:
per una nuova suggestiva scena
ora basta solo chiudere gli occhi.

façon de venise by
LIGHT4

LIGHT4 srl viale dell'industria, 2A - 31055 quinto di treviso (tv) - italia
t. +39 0422 378122 - t. +39 0422 475009 - f +39 0422 370409
www.facondevenise.com - www.light4.it - info@light4.it

