

clever

G R I F E R Í A

TARIFA 2017
PRICE LIST · TARIF



Bath & Kitchen
— COLLECTION —

clever

G R I F E R Í A

Grifería Clever nace en 1998 de **Standard Hidráulica S.A.U.**, empresa fundada en Barcelona en 1975 y reconocida como uno de los principales fabricantes de **grifería y accesorios para cocina y baño en España**. La **calidad**, el **servicio**, la **innovación** y el **exquisito diseño**, unido a una constante **investigación tecnológica** y una cuidada **atención al cliente**, son las bases de la filosofía empresarial de nuestra empresa.

Clever taps were launched in 1998 by Standard Hidraulica, company founded in 1975, well known as one of the main producers of taps and showers in Spain. Our company's philosophy is based in quality, service, innovation, exquisite design and technology investigation.

Clever est né en 1998 au sein de Standard Hidráulica S.A.U., une entreprise fondée à Barcelone en 1975, et reconnue comme l'un des principaux fabricants de robinetterie pour la cuisine, la salle de bains et les collectivités en Espagne. La qualité, le service, l'innovation et les designs exquis, combinés avec l'intégration constante des nouvelles technologies et le suivi attentif de notre clientèle sont les fondements de la philosophie d'entreprise de notre société.



NO VE DA DES 2017

News 2017
Nouveautés 2017

NOVEDADES

News / Nouveautés

2017

PLATINUM

Saona Slim
PÁG.44



STYLES

Agora **xtreme** PÁG.51



Lavabo cascada 60
Waterfall basin mixer / Mitigeur cascade



Start *elegance*
PÁG.70



Start **xtreme**
PÁG.73

Accesorios de Baño

NUEVOS Toalleros de 40cm
NEW Towel rails 40cms / Nouveaux porte-serviettes de 40cm

PLATINUM
elegance
xtreme
urban



PÁG.106-109



Conjunto de ducha extensible
Extensible shower system
Colonne mélangeur douche extensible



Ducha
Shower mixer
Mitigeur douche



Conjunto de ducha extensible termostático
Thermostatic extensible shower system
Colonne mélangeur douche extensible thermostatique

Nine *elegance*
PÁG.100

STYLES



Ducha termostática
Thermostatic shower mixer
Mitigeur douche thermostatique



Baño-ducha termostática
Thermostatic bath-shower mixer
Mitigeur bain-douche thermostatique

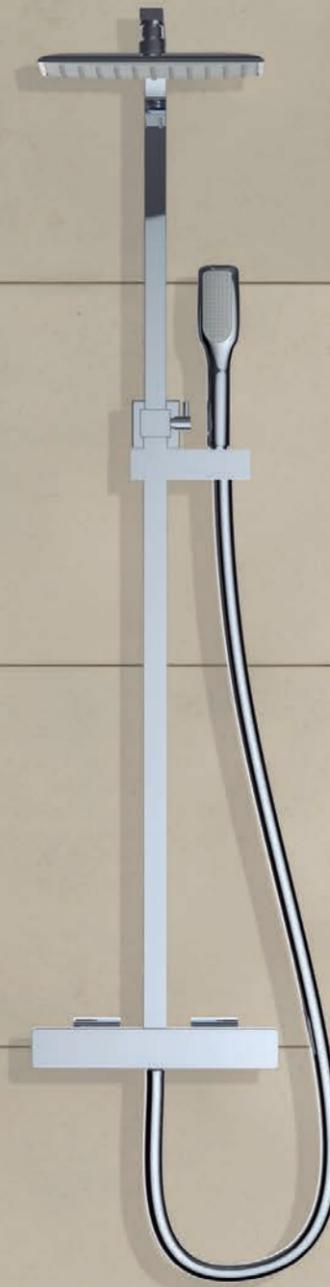

Conjunto de ducha extensible termostático
Thermostatic extensible shower system
Colonne mélangeur douche extensible thermostatique

NOVEDADES

News / Nouveautés

2017

Con caída lluvia y cascada, para grifería iclever.

With rain and waterfall effect for iClever mixers.
Avec effet pluie et cascade, pour la robinetterie iclever.



Rociador empotrado Angel

Concealed shower head
Pomme de douche encastré

PÁG.118

HydroClever



Rociador AutoClean

Shower head
 Pomme de douche
 PÁG.119

Rociador AutoClean (Autolimpiable)

PÁG.119

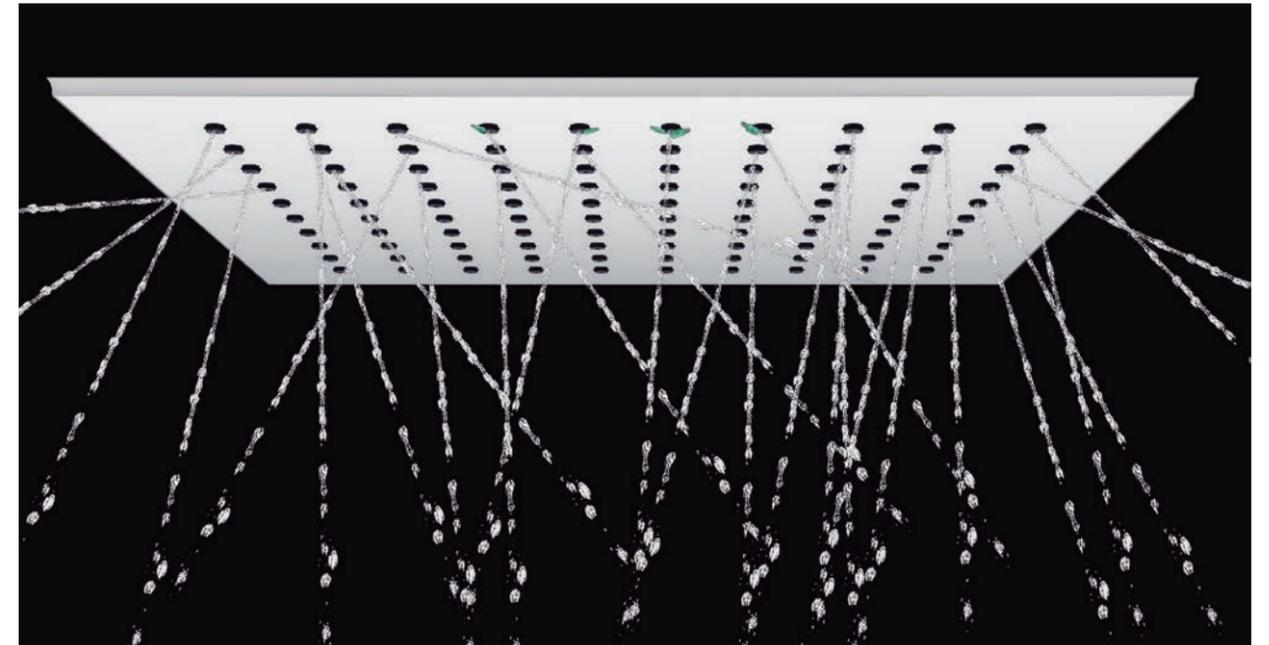

Debido al uso, la cal se posiciona gradualmente en los orificios de salida haciendo que el agua no caiga de forma uniforme. Con el rociador Auto limpiable evitamos esta situación.

After using it, the lime blocks the water outlets. With the rain shower self-cleaning we will avoid this situation.

Avec le temps, le calcaire se dépose progressivement sur les orifices de sortie ce qui entraîne une déformation du jet d'eau. Avec la pomme de douche autonettoyante nous évitons cet inconvénient.



El rociador Auto limpiable evita que se taponen los orificios de salida de agua a través de un sistema interno por agujas.

The shower rain self-cleaning avoids the water outlets to be blocked due to an internal system with needles.

La pomme de douche autonettoyante évite l'entartrage des jets d'eau, grâce à un dispositif intégré qui combine gravité et pression d'eau pour nettoyer les orifices.

El sistema consigue mantener la trayectoria original de la salida del agua ofreciendo una sensación natural de lluvia.

The system maintains the original water trajectory offering a natural rain sensation.

Ce dispositif permet au jet d'eau de conserver sa trajectoire originale vous offrant une sensation de pluie naturelle en permanence.

Rociador Syvari

Shower head
Pomme de douche
PÁG.119

Rociador y teléfono Hexagon

Shower head and handset
Pomme de douche et Douchette
PÁG.119,123



Teléfono Syvari

Handset
Douchette
PÁG.123



Rociador Beam

*Con salida de agua
a alta presión vaporizada*

Shower head
*High pressure outlet with
spray water sensation*

Pomme de douche
*Avec sortie d'eau à haute
pression vaporisée*

PÁG.119

NOVEDADES

News / Nouveautés

2017

Grifos de cocina

Chef Slim
PÁG.135



Descubre acabados y características en

Discover the finishes and characteristics in / Découvrez finitions et caractéristiques dans

www.griferiaclever.com/chefslim

NOVEDADES

News / Nouveautés

2017

Grifos de cocina

Chef 6
PÁG.135



Chef Essential Slim
PÁG.136



Chef Magnet Slim
PÁG.134



Sistema magnético
de sujeción de la pistola

*Magnet system to grab the dishwashing pull-out
Dispositif aimanté pour maintenir la douchette*



Descubre acabados y características en

Discover the finishes and characteristics in / Découvrez finitions et caractéristiques dans

www.griferiaclever.com

NOVEDADES

News / Nouveautés

2017

Nuevo sistema salida osmosis.
New outlet osmosis system / Nouveau système de sortie d'eau purifiée



Grifos de cocina

Square Abatible

Folding spout
Bec rabattable et orientable

PÁG.138



¡Solución práctica!
Con el grifo de cocina abatible
podrás abrir la ventana sin obstáculos.

Easy solution! With the sink mixer folding spout you will be able
to open the window without any issue.
Solution pratique! Grâce à votre robinet de cuisine rabattable
vous pourrez ouvrir la fenêtre sans le moindre obstacle.



Osmosis Round
PÁG.139



Osmosis Square
PÁG.139



NOVEDADES

News / Nouveautés

2017

Expositores Clever, perfectos para tu tienda.

*Floorstand, perfect for your shop.
Présentoir de comptoir, parfait pour votre comptoir.*



Expositores

PÁG. 180

Clever Five

Ideal para mostrar en un solo expositor un lavabo, bidet, ducha, baño-ducha y fregadero.

*Perfect to show in one display Basin, Bidet, Shower, Bath Shower and Sink mixer.
Idéal pour présenter sur un même présentoir un lavabo, un bidet, une douche, un bain-douche et un évier.*



iClever

Sólo válido para iclever2 y iclever4

*Just valid for iClever2 and iClever4
Seulement compatible avec iclever2 et iclever4*



Clever Shattaf

Sólo válido para shattaf
Ref. 97801, 97802, 97803 y 98442.

Y para todas las duchas higiénicas.

Just valid for Shattaf ref 97801, 97802, 97803 and 98442, and for all the hygienic showers. Seulement compatible pour les shataff ref. 97801, 97802, 97803 et 98442, ainsi que toutes les douchettes hygiéniques

Descubre todas las **NOVEDADES 2017** de nuestra App clever

Discover our new products 2017 in our Clever App / Découvrez toutes les nouveautés 2017 de notre App Clever



Realidad Aumentada
Baño y Cocina

Augmented reality
Bath & Kitchen
Réalité Augmentée
Bain et Cuisine

Dónde encontrar nuestro producto
Nuevo mapa de Distribuidores

Where to find our product.
New distributors map.

Où trouver nos produits.
Nouvelle carte des distributeurs.

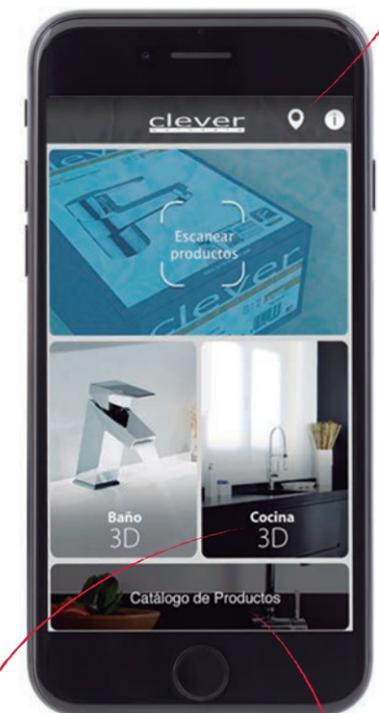

Nuestra gama de **Cocina**

Our kitchen range
Notre gamme de cuisine

Catálogo de productos

Product catalogue
Catalogue des produits



Download Clever App Free



PLATINUM



Ventu	32
Aude	34
Selene	35
Bimini	36
Marina Evo	40
Mikura	41
Saona Slim	44
Paula	45

STYLES



Agora elegance	50	Habana xtreme	68	S12 urban	87
Agora xtreme	51	Start elegance	70	With2 Antigona	90
Artic xtreme	52	Start xtreme	73	With2 Morea	93
Artic urban	54	Start urban	75	With2 Guayama	96
Caiman elegance	56	Panam elegance	77	Nine elegance	100
Caiman xtreme	60	Panam xtreme	78	Nine xtreme	101
Caiman urban	61	Panam urban	80	Nine urban	102
Bahama xtreme	64	S12 elegance	83		
Bahama urban	67	S12 xtreme	85		

Accesorios de Baño



Platinum	106
elegance	107
xtreme	108
urban	109

HidroClever



iClever	114	Teléfono ducha	122	Salida flexo	127
Rociadores	118	<i>Handsets</i>	<i>Douchettes</i>	<i>Wall outlet</i>	<i>Sortie flexible</i>
<i>Pomme de douche</i>		Soportes	125	Caños	128
Conjunto de ducha	121	<i>Wall brackets</i>	<i>Supports</i>	<i>Bath spouts</i>	<i>Bec</i>
<i>Shower kit</i>	<i>Kit douche</i>	Barras de ducha	126	Jets	128
Brazo rociador	122	<i>Slidings bars</i>	<i>Barre de douche</i>	Hidromasaje	
<i>Shower arm</i>		Flexibles	127	<i>Body jets</i>	<i>Jets</i>
<i>Brass pour pomme</i>	<i>de douche</i>	<i>Flexibles</i>	<i>Flexibles</i>		

Gama Box



Termostáticos	129
<i>Thermostatics</i>	
<i>Thermostatiques</i>	
Monomandos	130
<i>Single lever mixers</i>	
<i>Mitigeur</i>	
Sobremesa	131
<i>Floorstands</i>	
<i>Présentoirs</i>	

Grifos de cocina



Chef	134
Inox	138
Abatible	138
Osmosis	139
Platinum	140
Styles	140

Colectividades



Temporizados	148
<i>Delay action</i>	
<i>Temporisés</i>	
Ducha higiénica	149
<i>Shattaf</i>	
<i>Douche hygiénique</i>	
Grifos individuales	150
<i>Cold water taps</i>	
<i>Robinets individuels</i>	
Gerontológica	152
<i>Medical level operated</i>	
<i>Médical</i>	

Termostáticos



Termostáticos	154
<i>Thermostatics</i>	
<i>Thermostatiques</i>	
Termostáticos extensibles	158
<i>Adjustable Thermostatics</i>	
<i>Thermostatiques extensibles</i>	
Termostáticos no extensibles	159
<i>Non-adjustable Thermostatics</i>	
<i>Thermostatiques non extensibles</i>	
Monomandos extensibles	160
<i>Adjustable Single levers</i>	
<i>Mitigeurs extensibles</i>	

Sistemas de ducha y baño/ducha



Termostáticos extensibles	158
<i>Adjustable Thermostatics</i>	
<i>Thermostatiques extensibles</i>	
Termostáticos no extensibles	159
<i>Non-adjustable Thermostatics</i>	
<i>Thermostatiques non extensibles</i>	
Monomandos extensibles	160
<i>Adjustable Single levers</i>	
<i>Mitigeurs extensibles</i>	

CyR - Expositores



Complementos y Recambios	166
<i>Accessories and Spare parts</i>	
<i>Accessoires et Rechanges</i>	
Expositores	180
<i>Displays</i>	
<i>Présentoirs</i>	
Certificados	186
<i>Certificates</i>	
<i>Certificats</i>	
Condiciones de venta	189
<i>Sales conditions</i>	
<i>Conditions a vendre</i>	

¿QUÉ SIGNIFICA CADA ICONO?

What's the meaning of each **icon**?
Que signifie chaque **symbole**?

DISEÑO Y CALIDAD | DESIGN & QUALITY DESIGN ET QUALITÉ

- BAG PROTECT**
Funda algodón protectora
Cotton cover bag
Housse protectrice en coton
- PATENTED**
Diseño exclusivo y patentado
Exclusive and patent design
Design exclusif et breveté
- SAFETY BELT**
Fleje de seguridad antivandálico
Security plastic band
Feuillard de sécurité anti vandalisme
- TOP WARRANTY**
Garantía calidad 5 años
5 years warranty
Garantie qualité 5 ans

SEGURIDAD | SECURITY SÉCURITÉ

- MEDICAL**
Máxima higiene
Maximum hygiene
Hygiène maximale
- SAFETY BLOCK**
Doble tope de seguridad para termostáticos
Double security system for thermostatic
Double système de sécurité pour thermostatique
- TERMOLIMIT**
Limitación temperatura
Temperature limit
Limitation de la température
- THERMOSTATIC**
Regulación termostática, alta precisión
Thermostatic control, high precision
Contrôle thermostatique, haute précision

MATERIALES | MATERIALS | MATÉRIAUX

- CW617**
EXTRA BRASS
Latón de alta calidad
High quality brass
Laiton de haute qualité
- Cr**
EXTRA CHROME
Alta calidad cromado
High quality chrome
Chromage haute qualité
- MATT**
MATT
Acabado en mate
Matt finished
Fini mat
- INOX**
STAINLESS STEEL
Grifería de acero inoxidable
Stainless steel taps
Robinetterie acier inox

MEDIO AMBIENTE | ENVIRONMENT ENVIRONNEMENT

- AIR ADVANCED**
Mezcla aire y agua
Air and water mixture
Mélange d'air et de l'eau
- ECONATURE**
Cartucho C2/ec2 con 2 posiciones
C2/ec2 cartridge with 2 positions
Cartouche C2/ec2 avec 2 positions
- NOISELESS**
Dispositivo reductor de sonido
Noise reduction system
Système de réduction du bruit
- PUBLIC PLACE**
Diseñado para lugares públicos
Designed for public places
Conçu pour les lieux publics
- PURE H₂O**
Grifería para osmosis
Filter sink mixer
Robinet eau pure osmosis
- RECICLABLE**
Ecológico
Ecologic
Ecologique
- WATER REDUCE**
Sistema reducción de caudal
Flow reduction system
Système de réduction de débit

TECNOLOGÍA | TECHNOLOGY | TECHNOLOGIE

- ABATIBLE**
Con caño abatible
Folding spout
Bec rabattable et orientable
- AIR FORCE**
Aireadores de última generación
Last generation aerators
Aérateurs de dernière génération
- ANTI CAL**
Dispositivo anti-cal
Anti lime
Dispositif anticalcaire
- ANTI CAL**
Dispositivo anti-cal
Anti lime
Dispositif anticalcaire
- ANTISPLASH SYSTEM**
Anti salpicaduras
Antisplash
Anti-éclaboussures
- ANTITWIST**
Permite libre movimiento del teléfono respecto al flexo
Allows the hand shower to have free movement respect of the flexible
Permet un libre mouvement de la douchette sur le flexible
- CERAMIC CONTROL**
Discos cerámicos
Ceramic disc
Disques céramiques
- COLD OPEN**
Grifería anti-quemaduras
Anti-scald
Robinetterie anti-brûlures
- COLD TOUCH**
Grifería anti-quemaduras
Anti-scald
Robinetterie anti-brûlures
- CONNECTIONS**
Conexión 1/2"
Connection 1/2"
Connexion 1/2"
- EASYFIX**
Fácil instalación de fregaderos
Easy sink taps installation
Facilité d'installation des éviers
- EXTENSIBLE**
Tubo extensible
Adjustable shower bar
Barre extensible
- EXTRA LENGTH**
Flexible de 1,75m
Shower hose 1,75m
Flexible 1,75m
- HIDE DIVERTER**
Inversor diseño
Design diverter
Inverseur Design
- JET MASSAGE**
Grifería con jets de hidromasaje
Mixer with hydromassage jets
Robinetterie à jets hydromassants
- MAGNET**
Sistema magnético de sujeción
Magnetic systeme of subjection
Système magnétique de sujétion
- MIRROR EFFECT**
Pulido espejo
Mirror effect
Polissage miroir
- MULTIFUNCTION**
Diferentes efectos de salida del agua
Different kind of outlets effects
Différents effets de sortie d'eau
- Lluvia**
Rain
Pluie
- Masaje**
Massage
Massage
- Niebla**
Fog
Brouillard
- Spray**
- Espuma**
Foam
Mousse
- ORIENTABLE**
Aireador orientable
Easy sink taps installation
Aérateur orientable
- PULL-OUT**
Grifería extraíble
Pull-out taps
Robinetterie extractible
- SUPERFIX**
Anti-movimiento para sink fregaderos
Stop movement for sink mixer
Anti-mouvements éviers
- ULTRA SLIM**
Aireador enrasado
Concealed areator
Aérateur ultra slim
- ULTRA SLIM**
Rociadores mínimo grosor
Ultra Slim fixed heads
Pomme de douche
- WATERFALL**
Efecto cascada
Waterfall effect
Effet cascade



PLATINUM

Conceptual designs to feel your emotions.
Live your bathroom.

Griferías de diseño exclusivo, excelente calidad y con personalidad única.

High quality taps and showers, incorporating advanced technology, exclusive design & unique personality. The most universal taps and showers.

Robinetterie aux designs harmonieux, lignes pures et finitions surprenantes. Une robinetterie des plus universelles.



Ventu 32



Aude 34



Selene 35



Bimini 36



Marina Evo... 40



Mikura 41



Saona Slim .. 44



Paula 45

BAÑO-DUCHA REPISA | Four hole deck bath-shower
Mélangeur bain-douche 4 trous

Mezclador repisa, caño con aireador.
Four hole deck bath-shower mixer with aerator.
Mélangeur bain-douche 4 trous, aérateur



Ref.	€	
97060	400,00	4

Incluye Includes Inclus

Bali 96412

95167 90025

FREGADERO | Sink mixer | Mitigeur évier

Mezclador con aireador, caño conformado giratorio, flexibles M-10 3/8" x 370 mm.
Mixer with aerator, swivel tube spout, flexible hoses M-10 3/8" x 370 mm.
Mitigeur évier bec orientable, aérateur, raccords flexibles M-10 3/8" x 370 mm

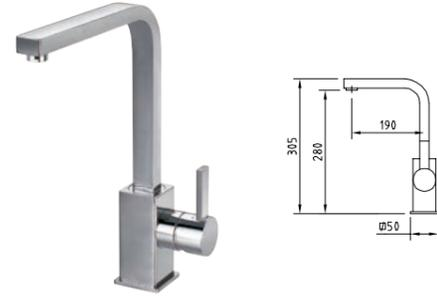

Ref.	€	
97046	219,00	8

ACS ec2

95165 97371 97688 96202

BAÑO-DUCHA EMPOTRAR - 2 VÍAS | Wall mounted bath-shower mixer-2 outlet diverter | Mitigeur à encastrer 2 voies

Mezclador empotrable 1/2" para baño-ducha, inversor automático.
Concealed bath-shower kit 1/2", automatic diverter.
Mitigeur encastré, 1/2", inverseur automatique



Ref.	€	
97997	203,00	8

ec2

97370 95178 98491

BAÑO-DUCHA EMPOTRAR - 1 VÍA | Wall mounted shower mixer-1 outlet diverter | Mitigeur à encastrer 1 voie

Mezclador empotrable 1/2" para ducha.
Concealed shower kit 1/2".
Mitigeur encastré, 1/2".



Ref.	€	
97998	156,00	8

ec2

97370 95178

CONJUNTO BAÑO-DUCHA EXTENSIBLE | Extensible bath-shower system | Colonne mitigeur bain-douche extensible

Mezclador de baño-ducha con tubo extensible.
Extensible bath-shower system.
Support douchette orientable, inverseur automatique, pomme de douche, douchette et flexible.

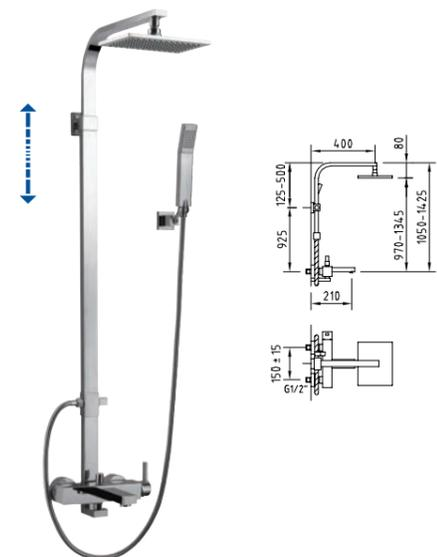

Ref.	€	
97055	976,00	3

ec2

Incluye Includes Inclus

145x220 97108 Marina 96786 1,75 m 97670 Pascua 97112

95165 97371 90027 60310



CONJUNTO DE DUCHA EXTENSIBLE | Extensible shower system | Colonne mitigeur douche extensible

Mezclador de ducha con tubo extensible.
Extensible shower system.
Support douchette orientable, inverseur automatique, pomme de douche, douchette et flexible

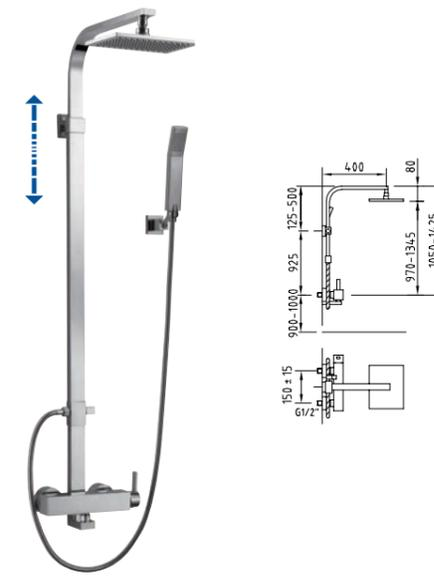

Ref.	€	
97056	938,00	3

ec2

Incluye Includes Inclus

145x220 97108 Marina 96786 1,75 m 97670 Pascua 97112

95165 97371 60310



CONJUNTO DE BAÑO-DUCHA TERMOSTÁTICO EXTENSIBLE | Extensible Thermostatic bath-shower system | Colonne thermostatique bain-douche extensible

Mezclador de baño-ducha termostático con tubo extensible.
Adjustable thermostatic bath-shower system.
Support douchette orientable, inverseur automatique/céramique, pomme de douche, douchette et flexible

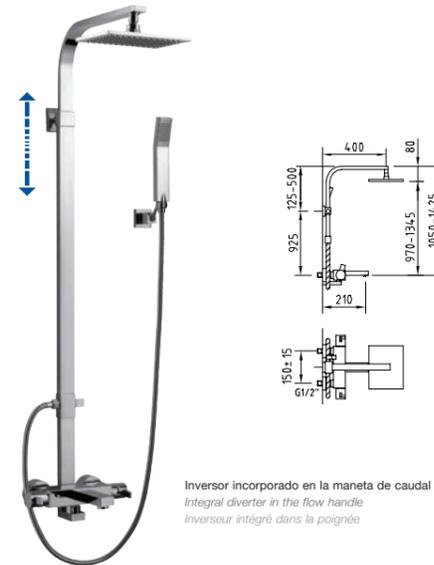

Ref.	€	
97057	1.164,00	3

ec2

Incluye Includes Inclus

145x220 97108 Marina 96786 1,75 m 97670 Pascua 97112

98027 90027 60310



CONJUNTO DE DUCHA TERMOSTÁTICO EXTENSIBLE | Extensible Thermostatic shower system | Colonne thermostatique douche extensible

Mezclador de ducha termostático con tubo extensible.
Adjustable thermostatic shower system.
Support douchette orientable, inverseur automatique, pomme de douche, douchette et flexible

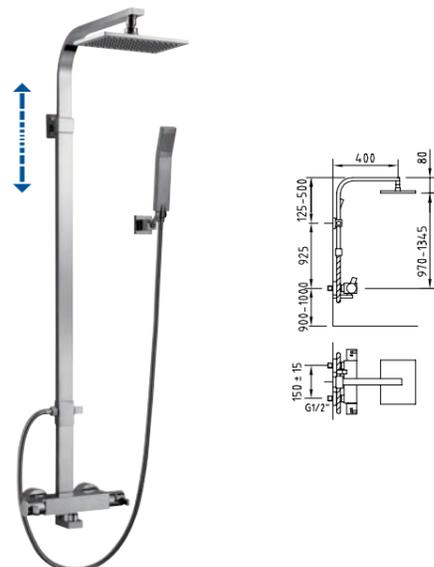

Ref.	€	
97058	1.032,00	3

ec2

Incluye Includes Inclus

145x220 97108 Marina 96786 1,75 m 97670 Pascua 97112

98027 90027 60310



BAÑO-DUCHA EMPOTRAR / 2 VÍAS | Wall mounted bath-shower mixer / 2 outlet diverter | Mitigeur à encastrer / 2 voies

Mezclador empotrable de 1/2" para baño-ducha, inversor automático.
Concealed bath-shower set 1/2", automatic diverter.
Mitigeur encastré, 1/2", inverseur automatique

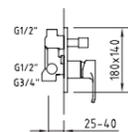

Ref.	€	Icon
ec1 98416	134,00	12



FREGADERO | Sink mixer | Mitigeur évier

Mezclador con rompeaguas, caño conformado giratorio, flexibles M-10 3/8" x 370 mm.
Mixer with water breaker, swivel tube spout, flexible hoses M-10 3/8" x 370 mm.
Mitigeur évier bec orientable, brise-jet, raccords flexibles M-10 3/8" x 370 mm

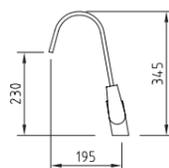

Ref.	€	Icon
ACS ec1 98201	161,00	8



CONJUNTO DE DUCHA EXTENSIBLE | Shower system | Colonne mitigeur douche extensible

Mezclador de ducha con tubo extensible.
Adjustable shower system.
Support douchette orientable, inverseur automatique, pomme de douche, douchette et flexible

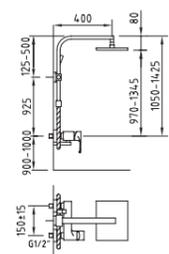

Incluye
Includes
Inclus



Ref.	€	Icon
ec1 98415	670,00	4

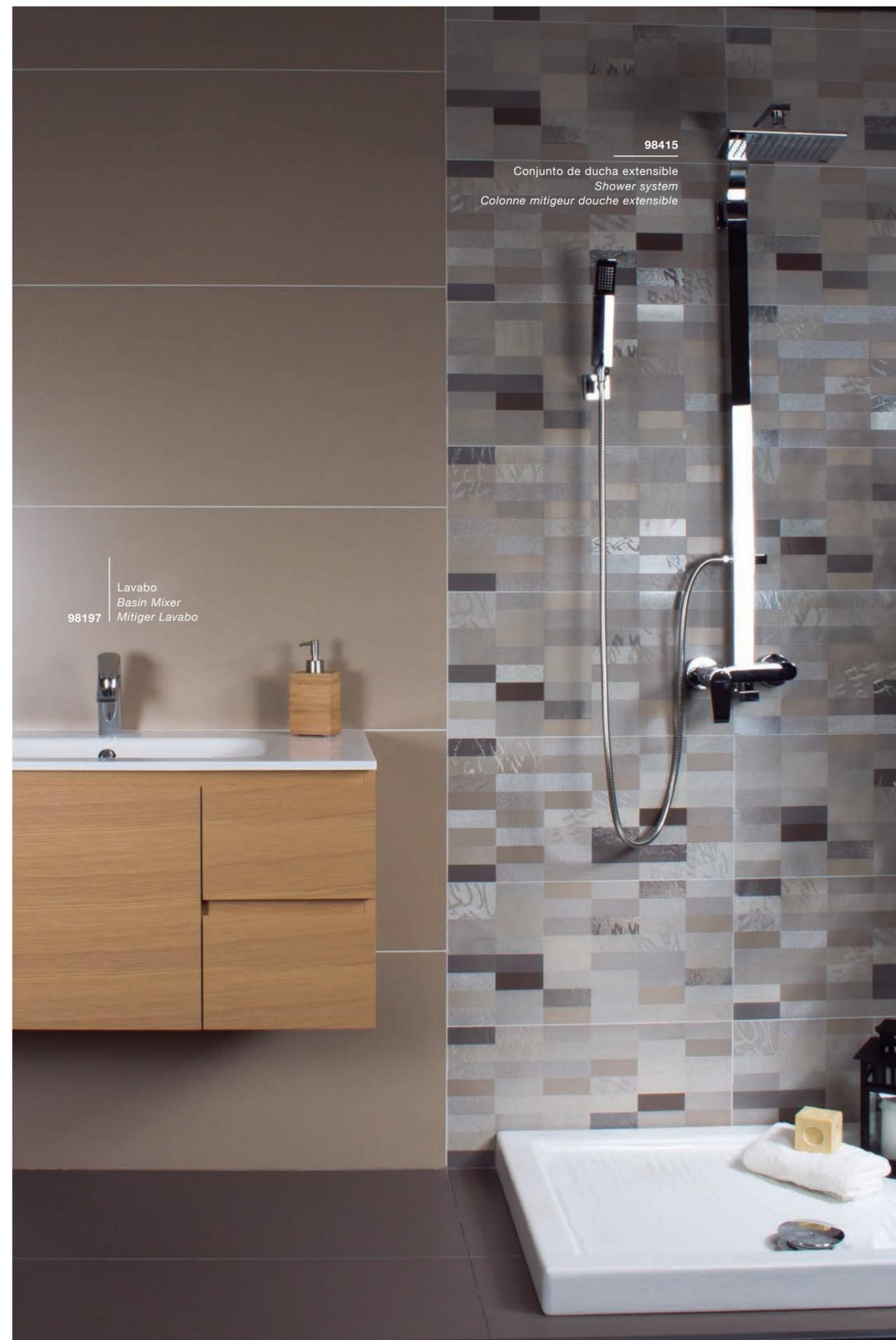

98197 Lavabo
Basin Mixer
Mitiger Lavabo

98415

Conjunto de ducha extensible
Shower system
Colonne mitigeur douche extensible

98199
Baño-Ducha
Bath-shower Mixer
Mitiger bain-douche

STYLES

Unlimited emotions. **Unlimited designs.**

Griferías de apacibles diseños y estilos, de líneas puras con acabados sorprendentes. La grifería más universal.

Taps and showers with soft designs, pure lines and different styles. The most universal taps and showers.

Robinetterie aux designs harmonieux, aux lignes pures et aux finitions surprenantes. Une robinetterie des plus universelles.



Agora

p.50



NEW

p.51



Artic

p.52



p.54



Caiman

p.56



p.60



p.61



Bahama

p.64



p.67



Habana

p.68



Start

p.70



p.73



p.75



Panam

p.77



p.78



p.80



S12

p.83



p.85



p.87



With2

p.90



p.93



p.96



Nine

NEW

p.100



NEW

p.101



p.102





LAVABO 235 | Basin mixer 235 | Mitigeur lavabo 235
 Mezclador con aireador y flexibles M-10 3/8" x 370 mm.
 Mixer, aerator, flexible hoses M-10 3/8" x 370 mm.
 Mitigeur Lavabo bec haut, aérateur, raccords flexibles M-10 3/8" x 370 mm

Ref.	€	
ACS ec3 98784	140,00	6



LAVABO 85 | Basin mixer 85 | Mitigeur lavabo 85
 Mezclador con aireador y flexibles M-10 3/8" x 370 mm.
 Mixer, aerator, flexible hoses M-10 3/8" x 370 mm.
 Mitigeur Lavabo, aérateur, raccords flexibles M-10 3/8" x 370 mm

Ref.	€	
ACS ec3 98690	100,00	12
ACS ec3 98695	108,00	12
ACS ec3 98696	116,00	12



BIDÉ | Bidet mixer | Mitigeur bidet
 Mezclador con aireador a rótula y flexibles M-10 3/8" x 370 mm.
 Mixer, swivel aerator, flexible hoses M-10 3/8" x 370 mm.
 Mitigeur bidet, aérateur rotule, raccords flexibles M-10 3/8" x 370 mm

Ref.	€	
ACS ec3 98691	100,00	12
ACS ec3 98697	108,00	12
ACS ec3 98698	116,00	12



BAÑO-DUCHA | Bath-shower mixer | Mitigeur bain-douche
 Mezclador baño-ducha, aireador, inversor automático
 Bath-shower mixer, aerator, automatic diverter.
 Mitigeur bain-douche, aérateur, inverseur automatique

Incluye teléfono ducha, flexo y soporte
 Includes handset, hose and holder
 Inclus douchette, flexible et support
 (90796, 97670, 98208)

Sin kit ducha
 Without shower kit
 Sans kit de douche

Ref.	€	
ec2 98692	146,00	8
ACS ec2 98699	126,00	8



DUCHA | Shower mixer | Mitigeur Douche
 Mezclador para ducha.
 Shower mixer.
 Mitigeur douche

Incluye teléfono ducha, flexo y soporte
 Includes handset, hose and holder
 Inclus douchette, flexible et support
 (90796, 97670, 98208)

Sin kit ducha
 Without shower kit
 Sans kit de douche

Ref.	€	
ec2 98693	116,00	8
ACS ec2 98700	96,00	8



FREGADERO | Sink mixer | Mitigeur Évier
 Mezclador con aireador, caño fundido giratorio, flexibles M-10 3/8" x 370 mm.
 Mixer with aerator, swivel cast spout, flexible hoses M-10 3/8" x 370 mm.
 Mitigeur évier bec orientable, aérateur, raccords flexibles M-10 3/8" x 370 mm

Ref.	€	
ACS ec3 98694	153,00	8



FREGADERO EXTRAÍBLE | Pull-out sink mixer | Mitigeur évier douchette extractible

Mezclador con aireador, caño giratorio, ducha extraíble con pulsador para lavavajillas, enlaces de alimentación flexibles M-10 3/8" x 370 mm.
 Mixer with aerator, swivel spout, pull-out handset and flexible hoses M-10 3/8" x 370 mm.
 Mitigeur évier bec orientable, aérateur, douchette extractible avec poussoir pré-lavage, raccords flexibles M-10 3/8" x 370 mm

Ref.	€	
ACS ec3 98689	183,00	4



FREGADERO | Sink mixer | Mitigeur Évier
 Mezclador con aireador, caño giratorio, flexibles M-10 3/8" x 370 mm.
 Mixer with aerator, swivel spout, flexible hoses M-10 3/8" x 370 mm.
 Mitigeur évier bec orientable, aérateur, raccords flexibles M-10 3/8" x 370 mm

Ref.	€	
ACS ec3 99108	143,00	4



Lavabo
 Basin Mixer
 98690
 Mitigeur Lavabo

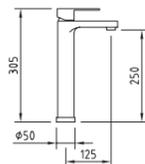

LAVABO 250 | Basin mixer 250 | Mitigeur lavabo 250

Mezclador con aireador y flexibles M-10 3/8" x 600 mm.
Mixer, aerator, flexible hoses M-10 3/8" x 600 mm.
Mitigeur Lavabo bec haut, aérateur, raccords flexibles M-10 3/8" x 600 mm



	Ref.	€	
ACS ec1	98103	162,00	12
ACS ec1	98112	170,00	12
ACS ec1	98111	178,00	12

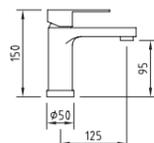

LAVABO 95 | Basin mixer 95 | Mitigeur lavabo 95

Mezclador con aireador y flexibles M-10 3/8" x 370 mm.
Mixer, aerator, flexible hoses M-10 3/8" x 370 mm.
Mitigeur Lavabo, aérateur, raccords flexibles M-10 3/8" x 370 mm



	Ref.	€	
ACS ec1	98102	120,00	12
ACS ec1	98110	128,00	12
ACS ec1	98109	136,00	12

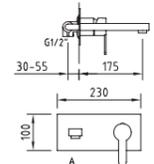
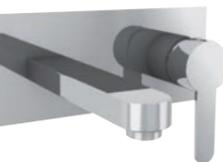

LAVABO EMPOTRAR | Concealed basin | Mitigeur lavabo à encastrer

Mezclador empotrable, caño mural con aireador, longitud 175mm.
Concealed basin, areator, wall spout length 175mm.
Mitigeur lavabo encastré, aérateur, bec 175 mm.



	Ref.	€	
ACS ec1	98470	196,00	12

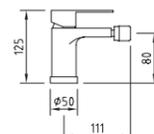

BIDÉ | Bidet mixer | Mitigeur bidet

Mezclador con aireador a rótula y flexibles M-10 3/8" x 370 mm.
Mixer, swivel aerator, flexible hoses M-10 3/8" x 370 mm.
Mitigeur bidet, aérateur rotule, raccords flexibles M-10 3/8" x 370 mm



	Ref.	€	
ACS ec1	98104	120,00	12
ACS ec1	98114	128,00	12
ACS ec1	98113	136,00	12

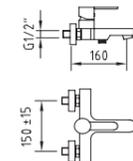

BAÑO-DUCHA | Bath-shower mixer | Mitigeur bain-douche

Mezclador baño-ducha, aireador, inversor automático.
Bath-shower mixer, aerator, automatic diverter.
Mitigeur bain-douche, aérateur, inverseur automatique intégré

Incluye teléfono ducha, flexo y soporte
Includes handset, hose and holder
Inclus douchette, flexible et support
(90796, 97670, 96458)

Sin kit ducha
Without shower kit
Sans kit de douche



	Ref.	€	
ACS ec1	98105	166,00	8
ACS ec1	98541	146,00	8



DUCHA | Shower mixer | Mitigeur Douche

Mezclador para ducha.
Shower mixer.
Mitigeur douche

Incluye teléfono ducha, flexo y soporte
Includes handset, hose and holder
Inclus douchette, flexible et support
(90796, 97670, 96458)

Sin kit ducha
Without shower kit
Sans kit de douche



	Ref.	€	
ACS ec1	98106	136,00	8
ACS ec1	98542	116,00	8

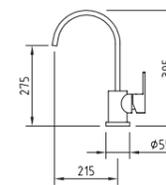

FREGADERO | Sink mixer | Mitigeur Évier

Mezclador con aireador, caño conformado giratorio, flexibles M-10 3/8" x 370 mm.
Mixer with aerator, swivel tube spout, flexible hoses M-10 3/8" x 370 mm.
Mitigeur évier bec orientable, aérateur, raccords flexibles M-10 3/8" x 370 mm



	Ref.	€	
ACS ec1	98107	153,00	5

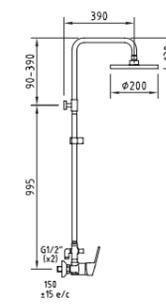

CONJUNTO DE DUCHA EXTENSIBLE | Extensible shower system | Colonne mitigeur douche extensible

Mezclador de ducha con tubo extensible.
Adjustable shower system.
Support douchette coulissant, inverseur automatique, pomme de douche, douchette et flexible

Incluye
Includes
Inclus



	Ref.	€	
ACS ec1	98474	430,00	2



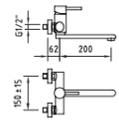

FREGADERO MURAL | Wall mounted single lever sink mixer | Mitigeur Évier mural

Mezclador mural con aireador, caño conformado giratorio inferior.
Wall mounted mixer with aerator, lower swivel tube spout.
Mitigeur évier mural, bec orientable façonné, aérateur

Ref.	€	
ACS ec1 97068	160,00	8

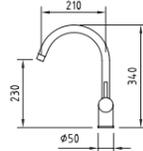

FREGADERO | Sink mixer | Mitigeur Évier

Mezclador con aireador, caño conformado giratorio, flexibles M-10 3/8" x 370 mm.
Mixer with aerator, swivel tube spout, flexible hoses M-10 3/8" x 370 mm.
Mitigeur évier bec orientable, aérateur, raccords flexibles M-10 3/8" x 370 mm

Ref.	€	
ACS ec1 97086	155,00	8

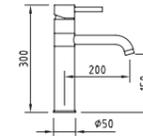

FREGADERO | Sink mixer | Mitigeur Évier

Mezclador con caño giratorio con aireador y flexibles M-10 3/8" x 600 mm.
Mixer, aerator swivel spout, flexible hoses M-10 3/8" x 600 mm.
Mitigeur évier bec orientable, aérateur, raccords flexibles M-10 3/8" x 600 mm

Ref.	€	
ACS ec1 60161	175,00	20

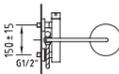
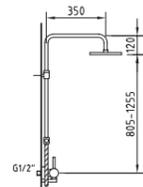
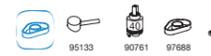

CONJUNTO DE DUCHA EXTENSIBLE | Extensible shower system | Colonne mitigeur douche extensible

Mezclador de ducha con tubo extensible, soporte articulado fijo.
Adjustable shower system with diverter.
Support douchette fixe, inverseur automatique, pomme de douche, douchette et flexible

Ref.	€	
ACS ec1 97079	645,00	4

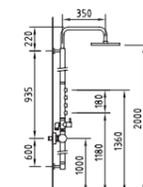

CONJUNTO DE DUCHA TERMOSTÁTICO 4 JETS | Thermostatic shower system 4 jets | Colonne thermostatique douche hydromassage

Mezclador de ducha termostático, 4 rociadores frontales de hidromasaje, soporte articulado fijo.
Adjustable thermostatic shower system with integral diverter and body jets.
4 jets, support douchette fixe, inverseurs céramiques, pomme de douche, douchette et flexible.

Ref.	€	
96436	1035,00	4



Fregadero
Sink mixer
Mitigeur évier
97086



BAÑO-DUCHA TERMOSTÁTICO | Thermostatic bath-shower mixer | Mitigeur bain-douche thermostatique

Mezclador baño-ducha, aireador, inversor automático
Bath-shower mixer, aerator, automatic diverter.
Mitigeur bain-douche thermostatique, aérateur, inverseur automatique

Incluye teléfono ducha, flexo y soporte
Includes handset, hose and holder
Inclus douchette, flexible et support
(90796, 97114, 97113)

Sin kit ducha
Without shower kit
Sans kit de douche

Ref.	€	
97012	392,00	8
98158	372,00	8



DUCHA TERMOSTÁTICA | Thermostatic shower mixer | Mitigeur douche thermostatique

Mezclador para ducha.
Shower mixer.
Mitigeur douche thermostatique

Incluye teléfono ducha, flexo y soporte
Includes handset, hose and holder
Inclus douchette, flexible et support
(90796, 97114, 97113)

Sin kit ducha
Without shower kit
Sans kit de douche

Ref.	€	
97013	333,00	8
98159	313,00	8



FREGADERO | Sink mixer | Mélangeur évier

Mezclador con aireador, caño conformado giratorio, flexibles M-10 3/8" x 370 mm.
Mixer with aerator, swivel tube spout, flexible hoses M-10 3/8" x 370 mm.
Mélangeur évier, bec orientabl, eaérateur, raccords flexibles M-10 3/8" x 370 mm

Ref.	€	
97005	137,00	8



**BAÑO-DUCHA FIJACIÓN SUELO
Floor standing bath-shower mixer |
Mélangeur bain-douche sur colonnes avec prise d'eau au sol**

Baño ducha fijación suelo, aireador, inversor.
Floor standing bath-shower mixer, aerator, diverter.
Mélangeur bain-douche sur colonne avec prise d'eau au sol, aérateur, inverseur automatique

Incluye teléfono ducha y flexo
Includes handset and hose
Inclus douchette et flexible
(90796, 97114)

Ref.	€	
97020	668,00	6

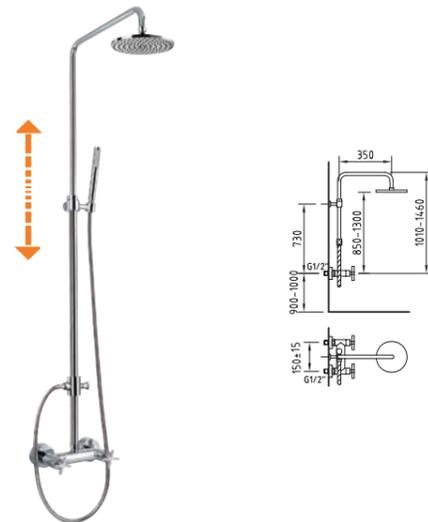
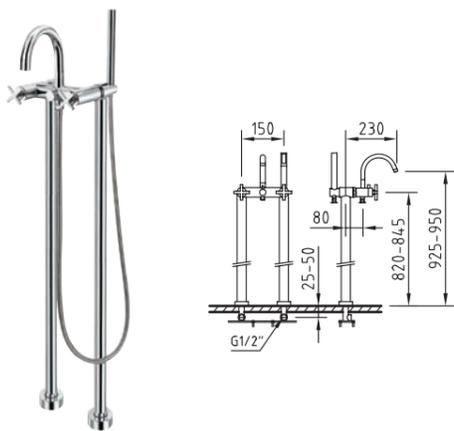

CONJUNTO DE DUCHA EXTENSIBLE | Extensible shower system | Colonne mélangeur douche extensible

Mezclador deducha con tubo extensible, soporte articulado fijo.
Adjustable shower system with diverter.
Support douchette fixe, inverseur automatique, pomme de douche, douchette et flexible

Incluye
Includes
Inclus
Ø200
97109
Caiman
90796
1,80 m
97114

Ref.	€	
97015	646,00	4

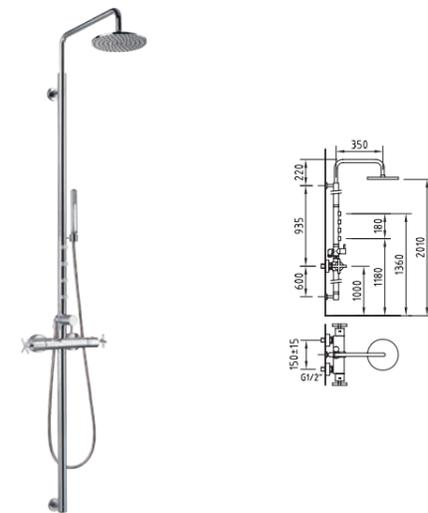

**CONJUNTO DE DUCHA TERMOSTÁTICO 4 JETS |
Thermostatic shower system 4 jets | Colonne thermostatique
douche hydromassage**

Mezclador de ducha termostático, 4 rociadores frontales de hidromasaje, soporte articulado fijo.
Adjustable thermostatic shower system with integral diverter and body jets.
4 jets, support douchette fixe, inverseurs céramiques, pomme de douche, douchette et flexible

Incluye
Includes
Inclus
Ø200
97109
Caiman
90796
1,80 m
97114

Ref.	€	
97018	1.036,00	4



97001
Lavabo
Basin mixer
Mitigeur lavabo

DUCHA TERMOSTÁTICA | Thermostatic shower mixer | Mitigeur douche thermostatique

Mezclador termostático para ducha.
Thermostatic shower mixer.
Mitigeur douche thermostatique

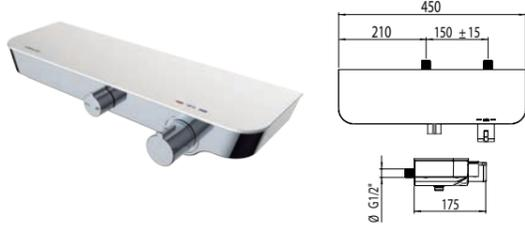

Incluye teléfono ducha, flexo y soporte
Includes handset, hose and holder
Inclus douchette, flexible et support
(99611, 98880, 60311)

Ref.	€	
60154	360,00	-



BAÑO-DUCHA TERMOSTÁTICO | Thermostatic bath-shower mixer | Mitigeur bain-douche thermostatique

Mezclador baño-ducha, aireador y inversor
Bath-shower mixer, aerator and diverter.
Mitigeur bain-douche thermostatique, aérateur et inverseur



Inversor incorporado en la maneta de caudal
Integral diverter in the flow handle
Inverseur intégré dans la poignée

Incluye teléfono ducha, flexo y soporte
Includes handset, hose and holder
Inclus douchette, flexible et support
(98880-99609-60313)

Sin kit ducha
Without shower kit
Sans kit de douche

Ref.	€	
60131	300,00	-
60132	280,00	-



CONJUNTO DE DUCHA EXTENSIBLE TERMOSTÁTICO | Thermostatic Extensible shower system | Colonne mélangeur douche extensible thermostatique

Mezclador termostático de ducha con tubo extensible (98517), soporte articulado deslizante.
Adjustable thermostatic shower system (98517) with integral diverter.
Support douchette coulissant, inverseur céramique, pomme de douche, douchette et flexible

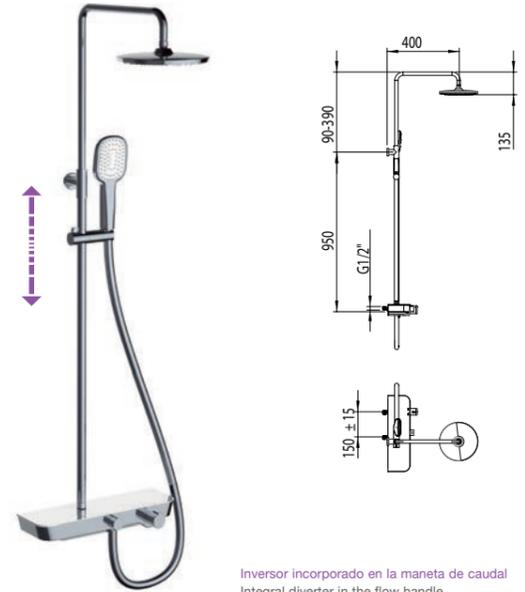

Incluye
Includes
Inclus



Style Air
240x190
99606

Style Air
100x120
99611

Silver Hose
1,75 m
98880

Ceilan
96264

Ref.	€	
99731	530,00	-



Inversor incorporado en la maneta de caudal
Integral diverter in the flow handle
Inverseur intégré dans la poignée

DUCHA TERMOSTÁTICA | Thermostatic shower mixer | Mitigeur douche thermostatique

Mezclador para ducha.
Shower mixer.
Mitigeur douche thermostatique



Incluye teléfono ducha, flexo y soporte
Includes handset, hose and holder
Inclus douchette, flexible et support
(98880-99609-60313)

Sin kit ducha
Without shower kit
Sans kit de douche

Ref.	€	
60133	255,00	-
60134	235,00	-



CONJUNTO DE DUCHA EXTENSIBLE | Extensible shower system | Colonne mélangeur douche extensible

Mezclador de ducha con tubo extensible Circular (98517), soporte articulado deslizante.
Adjustable shower valve with integral diverter.
Support douchette coulissant, inverseur automatique, pomme de douche, douchette et flexible

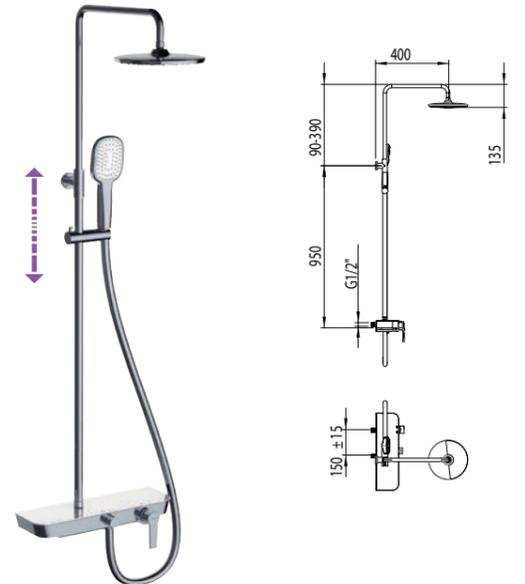

Incluye
Includes
Inclus



Style Air
240x190
99606

Style Air
100x120
99611

Silver Hose
1,75 m
98880

Ceilan
96264

Ref.	€	
99732	460,00	-



Inversor incorporado en la maneta de caudal
Integral diverter in the flow handle
Inverseur intégré dans la poignée

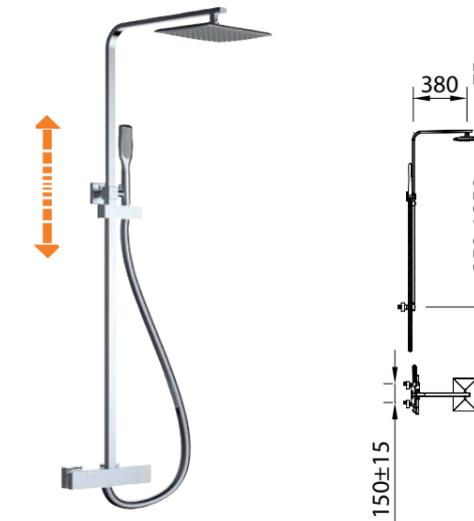

Inversor incorporado en la maneta de caudal
Integral diverter in the flow handle
Inverseur intégré dans la poignée

CONJUNTO DE DUCHA EXTENSIBLE TERMOSTÁTICO | Thermostatic Extensible shower system | Colonne mélangeur douche extensible thermostatique



Style Air
260x190
99608

Style Air
100x120
99609

Silver Hose
1,75 m
98880

Ref.	€	
60135	475,00	-





ACCESORIOS DE BAÑO

Bathroom accessories
Accessoires de salle de bain

-  **PLATINUM** 106
-  *elegance* 107
-  **xtreme** 108
-  *urban* 109



Un universo de posibilidades

Sumérgete en el inmenso universo de armonía, equilibrio y bienestar que te ofrece HidroClever.

Clever te abre un abanico de productos para que tu baño sea lo que siempre has imaginado que debería ser, escoge cada uno de los accesorios y combínalos de forma única para obtener tu baño ideal y dedícate tiempo para disfrutar, para relajarte y dejarte llevar en tu Spa urbano.

Ya que los baños no son iguales para todas las personas, combina todas nuestras posibilidades!

Te presentamos el revolucionario sistema de instalación iClever para los grifos de lavabo, ducha y baño-ducha empotrados. Tú eliges la caja empotrada de grifería manual o termostática que desees y luego escoges el modelo de grifería de nuestra colección que se complementa mejor para tu baño.

Dive into the vast universe of harmony, balance and relaxation, offered by HidroClever.

Clever provides you with a huge range of products for the bathroom you have always imagined, choose each of the accessories and combine them in order to get your ideal bathroom and allow yourself to enjoy it, relax and chill out in your urban Spa.

As bathrooms are not the same for everyone, combine all our Clever possibilities!

We introduce you to the revolutionary iClever system, concealed box for basins, showers and Bath-showers. You choose the iclever box, manual or thermostatic technology as you want, and then choose the most suitable mixer from our collection.

Plongez-vous dans l'immense univers d'harmonie, d'équilibre et bien-être que vous offre HidroClever.

Clever vous ouvre un éventail de produits pour que votre salle de bain soit telle que vous l'avez toujours rêvé, choisissez chacun des accessoires et combinez-les de façon unique pour obtenir votre salle de bain idéale et prenez le temps de profiter, de vous détendre et de vous laissez aller dans votre Spa urbain.

Puisque les salles de bains ne sont pas les mêmes pour tout le monde, combinez toutes nos possibilités.

Nous vous présentons le système révolutionnaire d'installation iClever pour les robinets de lavabo, de douche et bain-douche encastrés. Vous sélectionnez la boîte encastrée de robinetterie manuelle ou thermostatique de votre choix et vous choisissez le modèle de robinet de notre collection qui s'adapte le mieux à votre salle de bain.

PERSONALIZA TU BAÑO

Customize your bathroom
Personnalisez votre salle de bain



iclever 114
iclever basin
iclever 2
iclever 4



Rociadores 118
Shower heads
Pomme de douche



Conjunto ducha 121
Shower kit
Ensemble barre
douche



Brazo rociador 122
Shower arm
Bras de douche



Teléfono duchas 122
Handsets
Douchettes



Soportes 125
Wall brackets
Supports



Barras de ducha 126
Sliding bars
Barre de douche



Flexibles 127
Flexibles
Flexibles



Salida flexo 127
Wall outlet
Sortie flexible



Caños 128
Bath Spouts
Bec



Jets Hidromasaje 128
Body Jets
Jets

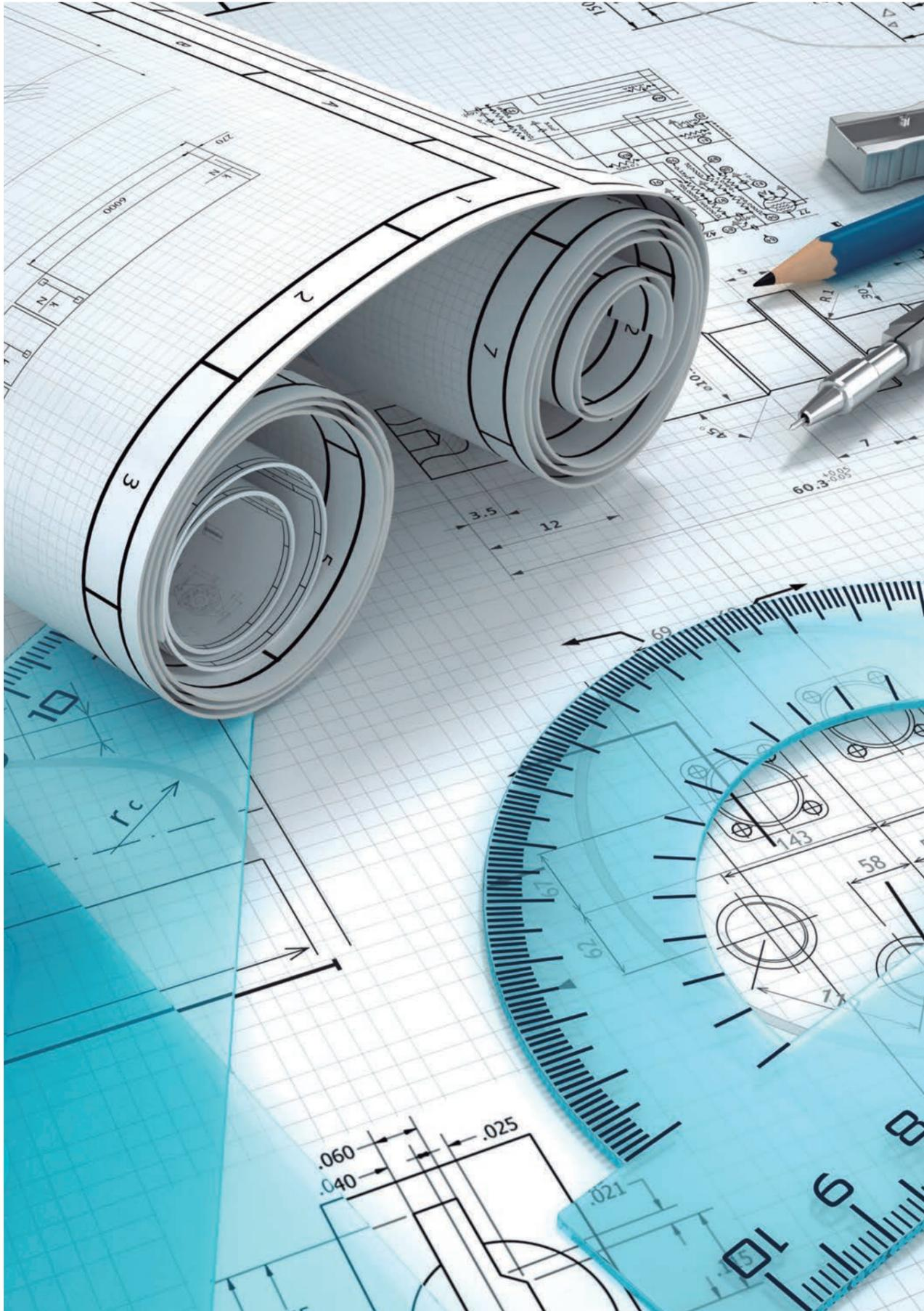

CERTIFICADOS

Certificates
Certificats 186

CONDICIONES DE VENTA

Sales cinditions
Conditions a vendre 189

Every design, an emotion



www.griferiaclever.com



@CleverGriferia



GriferiaClever



GriferiaClever

Standard Hidráulica, S.A.U.
Avenida La Ferrería, 73-75 · Pol. Ind. La Ferrería
08110 - Montcada i Reixac · Barcelona - Spain
Tel. +34 93 564 10 94 · info@griferiaclever.com

 **Standard Hidráulica**

COMAP
SOLUTIONS FOR EFFICIENCY