

Logica | Tiago

by Studio Hannes Wettstein

Logica | Tiago

by Studio Hannes Wettstein

Tiago

Overview 3

Technical data

Desks | Desk cabinets 26

Tables 29

Modular tables 34

Cabinets 36

Modular cabinets 39

Accessories 42

Materials & finishes 45

Technical notes 46

Addendum

About Logica 48

Interna Group 50

Tiago, the essence of prestige

Logica, Italian company part of the industrial group Interna - specialised in the production of high-end furniture for the contract, hospitality and office sectors – for more than 25 years offered furniture systems for every workplace, from the operative to the executive, up to the presidential ones. Furthermore Logica completes turnkey furniture projects in every part of the world. Its offer ranges from feasibility studies to production, from assembly to shipping, from testing to after-sales services, integrating standard products with exclusively designed articles, conceived and created ad hoc for each specific space.

The **Tiago system**, design by the Studio Hannes Wettstein based in Zurich, with its rigorous lines and important volumes, has been conceived for individual workspaces with a strong identity.

Tiago interprets the emotion of wood through three sophisticated and elegant essences that express solidity, strength and warmth: ebony, walnut, and wenge.

Quality of materials, highest levels of manufacture and care of every single detail allow the pure design of this collection to transcend all trends.





Born from the passion of a skilled Italian company, inspired by the charm of pure wood, the furnishings of the Tiago collection burst with powerful volumes and offer a complete executive system that combines wellness, functionality and beauty.





Tiago aims to give form to the functions of an executive space: reflect, meet, hold, and work in perfect autonomy. The generous built-in desk cabinet, composed of three large customizable containing parts, to hold file folders and printer, with electrification and cabling up to the work plan, is designed to allow operating in the utmost independence.





Tiago, proposed in ebony, walnut and wenge, with a leg in polished chrome finish, explores the many possible expressive combinations of precious woods and large metal bands. In this dynamic and refined merge, the play of light and shadows on the metal becomes intriguing and highlights deep and nuanced tones. In contrast, balancing the whole, the drop-front drawer, the inside of the drawers, the desk pad resting on desk tops and meeting tables are proposed in elegant matt leather.





The meeting tables can be single tables or tops and modular structures combined to allow extreme design flexibility.

Any design requirement can be satisfied in terms of measures, materials and finishes of each single item.

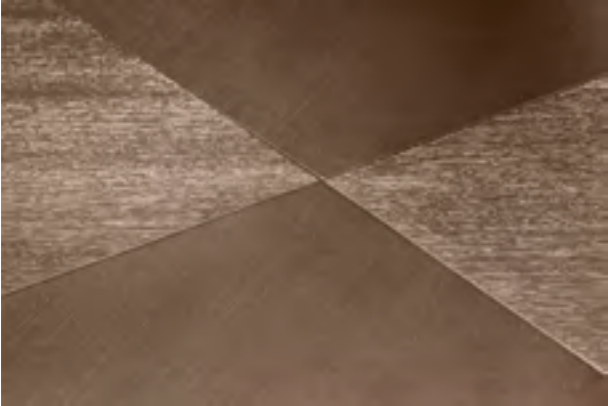







Technical data

The collection Tiago is a flexible 'tool' designed to meet any design requirement and operational need, and, as such, each item can be customized in terms of materials, finishes and dimensions.

The catalogue present our codified proposals, but each item can be produced in different sizes and using different materials and finishes, though their use will have to be evaluated beforehand on an individual basis, taking into consideration the technical feasibility and the end-use of the products.



Desks

DESK

L.TI.001.01

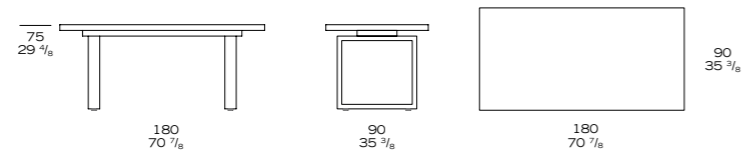

FINISHES

top:
ebony EC
american walnut NR
wenge WG

structure:
polished chrome CL

DESK

L.TI.001.02

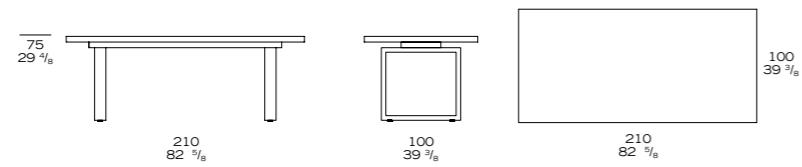

FINISHES

top:
ebony EC
american walnut NR
wenge WG

structure:
polished chrome CL

DESK

L.TI.001.03

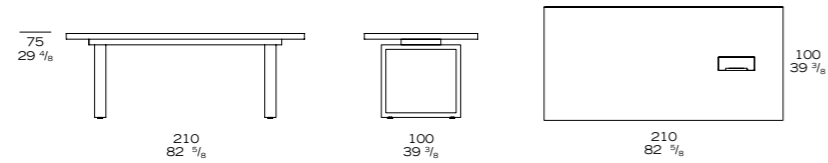

FINISHES

top:
ebony EC
american walnut NR
wenge WG

structure:
polished chrome CL

DESK

L.TI.001.04

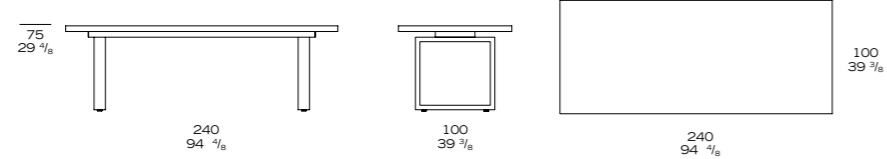

FINISHES

top:
ebony EC
american walnut NR
wenge WG

structure:
polished chrome CL

DESK

L.TI.001.05

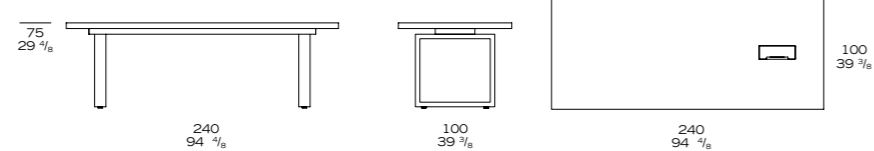

FINISHES

top:
ebony EC
american walnut NR
wenge WG

structure:
polished chrome CL

Desks

MODESTY PANEL - Desk two legs

FINISHES

L.TI.002.01

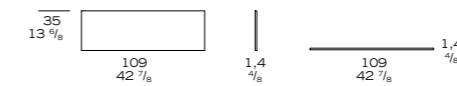

structure:
leather P3 black, moka
ebony EC
american walnut NR
wenge WG

L.TI.002.02

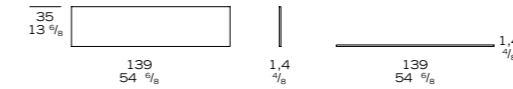

L.TI.002.03

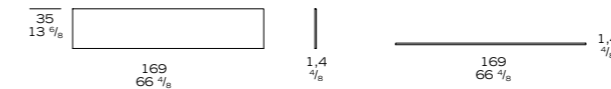

DESK

L.TI.003.01

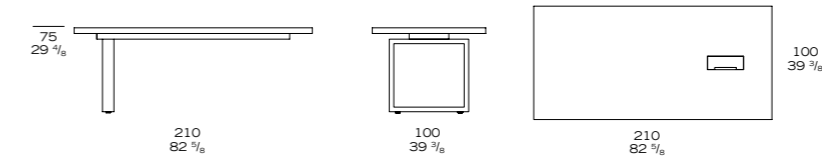

FINISHES

top:
ebony EC
american walnut NR
wenge WG

structure:
polished chrome CL

DESK

L.TI.003.02

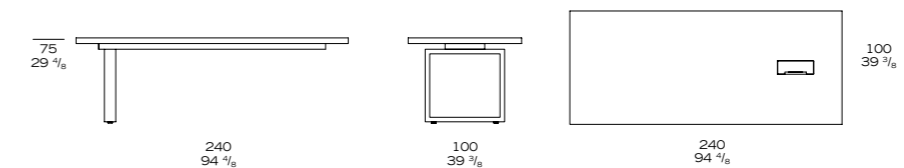

FINISHES

top:
ebony EC
american walnut NR
wenge WG

structure:
polished chrome CL

RETURN / 2 doors - 2 drawers - 1 filing

FINISHES

L.TI.004.01 DX

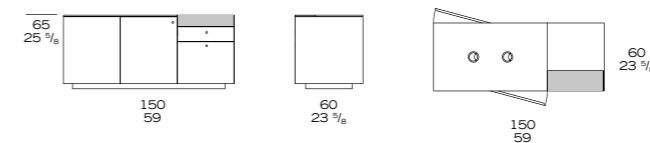

structure:
ebony EC
american walnut NR
wenge WG

drop-front drawers:
leather P3 black, moka

veneered inside cabinet;
drawers and filing
lacquered according to
leather color tone

Any design requirement can be satisfied by choosing customized materials, finishes and dimensions.

Any design requirement can be satisfied by choosing customized materials, finishes and dimensions.

Desks

RETURN / 2 doors - 2 drawers - 1 filing

L.TI.004.02 SX

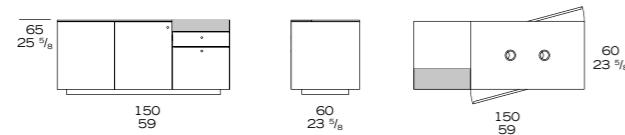

FINISHES

structure:
ebony EC
american walnut NR
wenge WG

drop-front drawers:
leather P3 black, moka

veneered inside cabinet;
drawers and filing lacquered
according to leather color tone

RETURN / 2 doors - 2 drawers - 1 filing

L.TI.004.03 DX

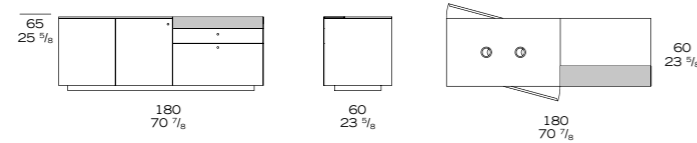

FINISHES

structure:
ebony EC
american walnut NR
wenge WG

drop-front drawers:
leather P3 black, moka

veneered inside cabinet;
drawers and filing lacquered
according to leather color tone

RETURN / 2 doors - 2 drawers - 1 filing

L.TI.004.04 SX

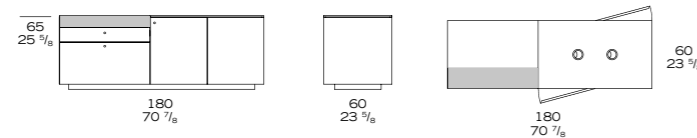

FINISHES

structure:
ebony EC
american walnut NR
wenge WG

drop-front drawers:
leather P3 black, moka

veneered inside cabinet;
drawers and filing lacquered
according to leather color tone

MODESTY PANEL - Desk with return

L.TI.005.01

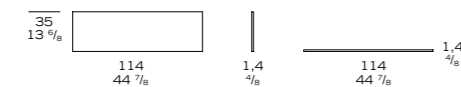

FINISHES

structure:
leather P3 black, moka
ebony EC
american walnut NR
wenge WG

L.TI.005.02

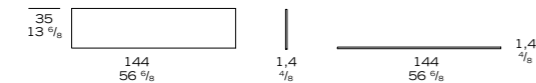

Tables

TABLE

L.TI.010.01

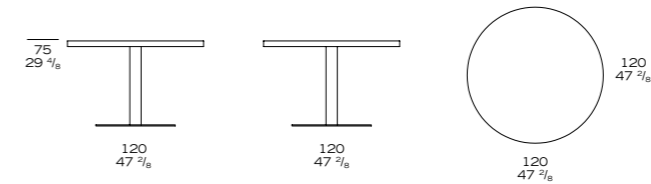

FINISHES

top:
ebony EC
american walnut NR
wenge WG

structure:
polished chrome CL

TABLE

L.TI.010.02

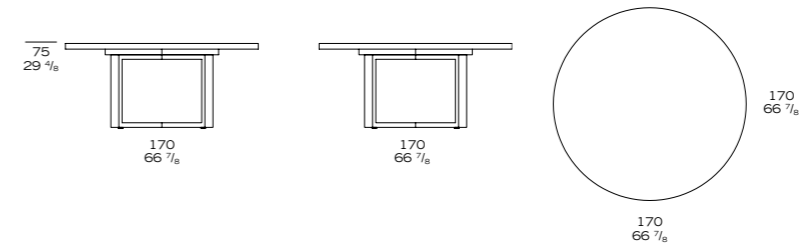

FINISHES

top:
ebony EC
american walnut NR
wenge WG

structure:
polished chrome CL

TABLE

L.TI.010.03

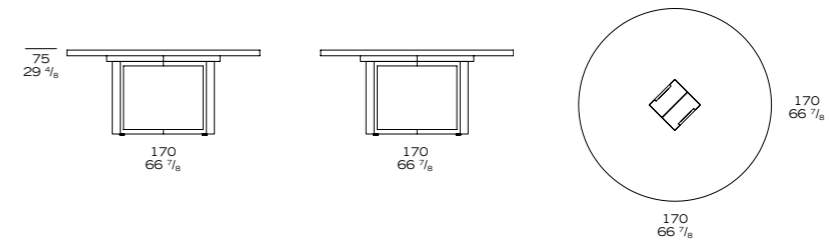

FINISHES

top:
ebony EC
american walnut NR
wenge WG

structure:
polished chrome CL

TABLE

L.TI.010.04

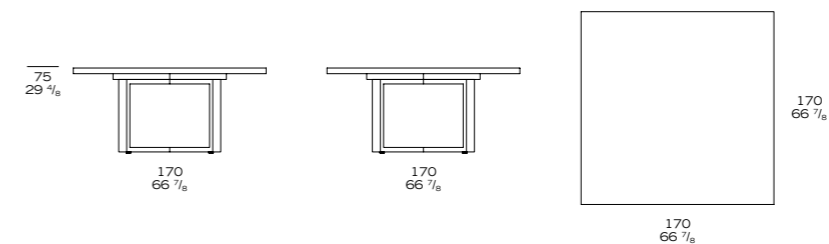

FINISHES

top:
ebony EC
american walnut NR
wenge WG

structure:
polished chrome CL

Tables

TABLE

L.TI.010.05

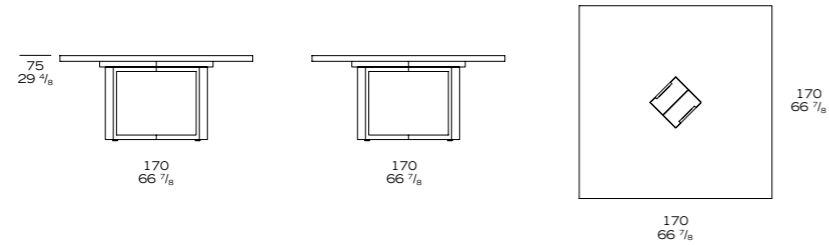

FINISHES

top:
ebony EC
american walnut NR
wenge WG

structure:
polished chrome CL

TABLE

L.TI.010.06

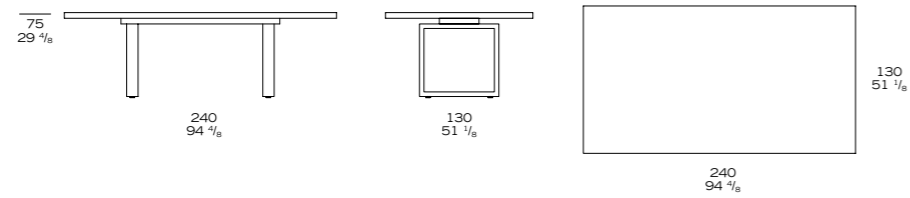

FINISHES

top:
ebony EC
american walnut NR
wenge WG

structure:
polished chrome CL

TABLE

L.TI.010.07

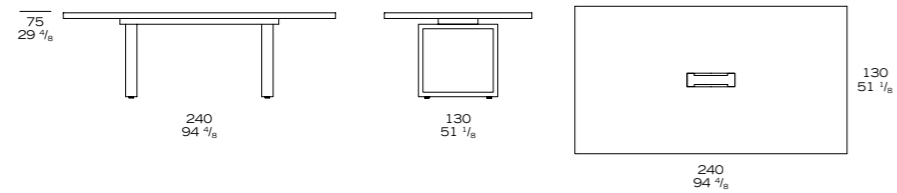

FINISHES

top:
ebony EC
american walnut NR
wenge WG

structure:
polished chrome CL

TABLE

L.TI.010.08

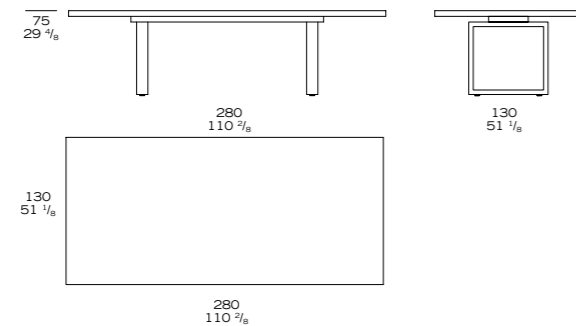

FINISHES

top:
ebony EC
american walnut NR
wenge WG

structure:
polished chrome CL

Tables

TABLE

L.TI.010.09

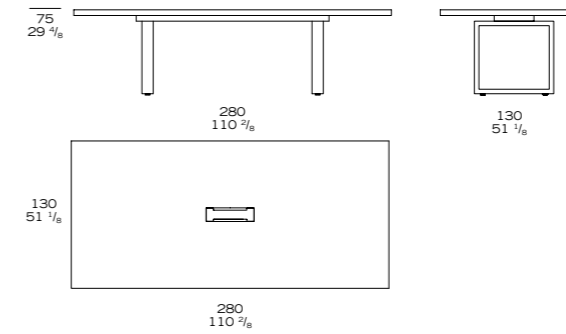

FINISHES

top:
ebony EC
american walnut NR
wenge WG

structure:
polished chrome CL

TABLE

L.TI.010.10

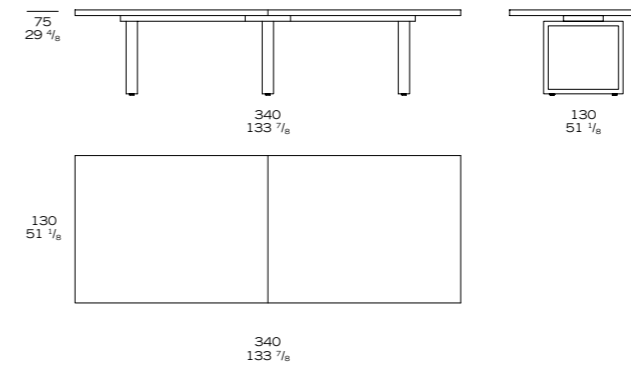

FINISHES

top:
ebony EC
american walnut NR
wenge WG

structure:
polished chrome CL

TABLE

L.TI.010.11

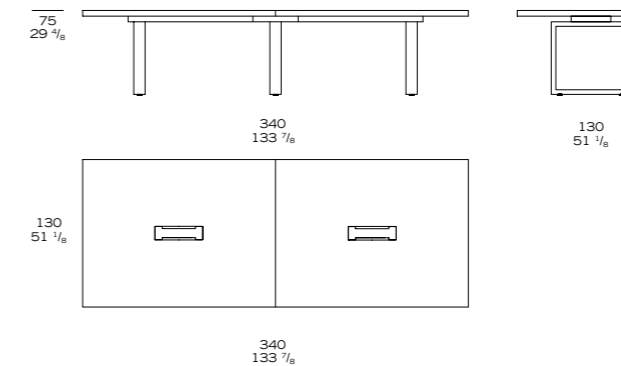

FINISHES

top:
ebony EC
american walnut NR
wenge WG

structure:
polished chrome CL

Any design requirement can be satisfied by choosing customized materials, finishes and dimensions.

Any design requirement can be satisfied by choosing customized materials, finishes and dimensions.

Tables

TABLE

L.TI.010.12

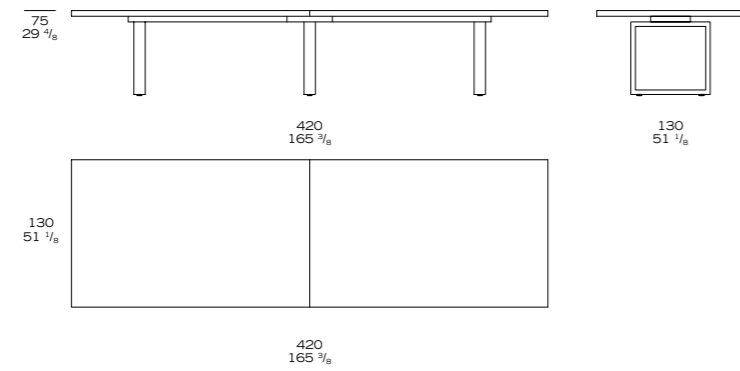

FINISHES

top:
ebony EC
american walnut NR
wenge WG

structure:
polished chrome CL

TABLE

L.TI.010.13

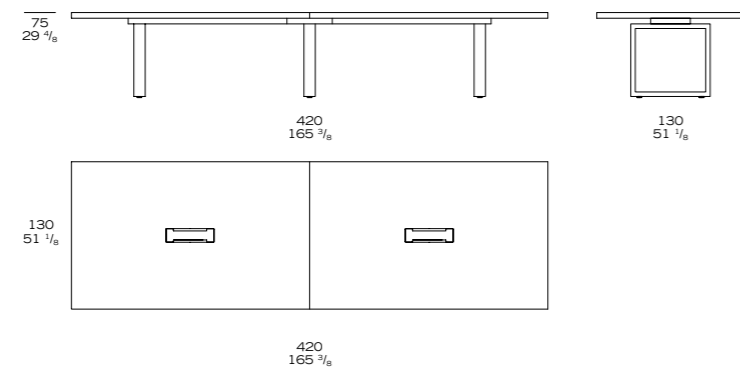

FINISHES

top:
ebony EC
american walnut NR
wenge WG

structure:
polished chrome CL

TABLE

L.TI.010.14

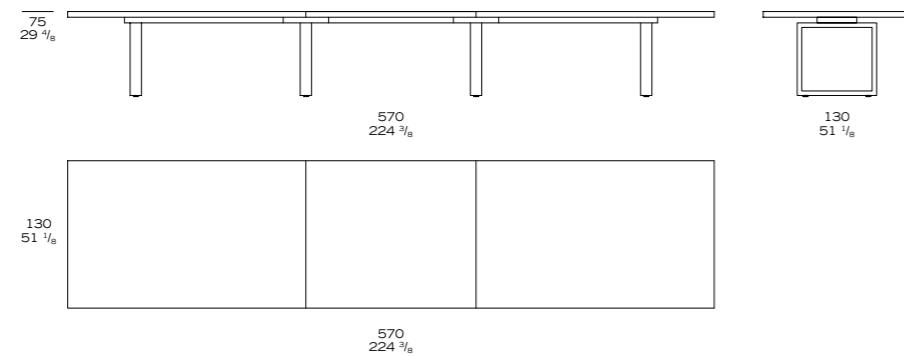

FINISHES

top:
ebony EC
american walnut NR
wenge WG

structure:
polished chrome CL

Any design requirement can be satisfied by choosing customized materials, finishes and dimensions.

Tables

TABLE

L.TI.010.15

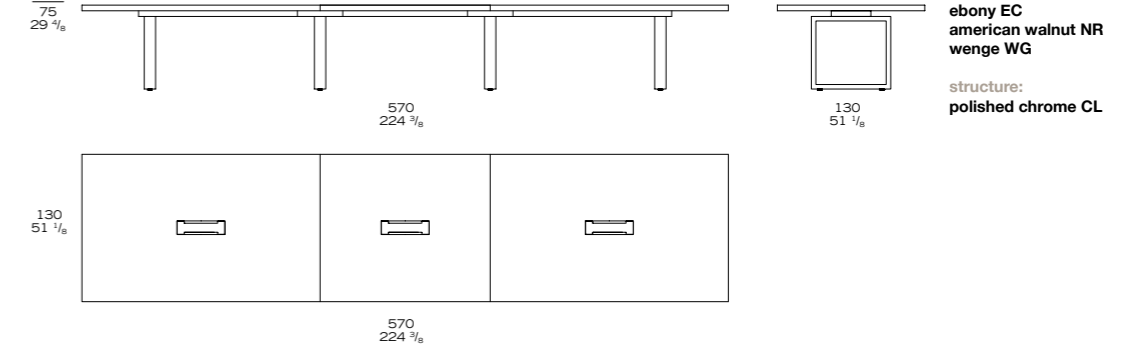

FINISHES

top:
ebony EC
american walnut NR
wenge WG

structure:
polished chrome CL

Any design requirement can be satisfied by choosing customized materials, finishes and dimensions.

Modular tables

END ELEMENT

L.TI.011.01

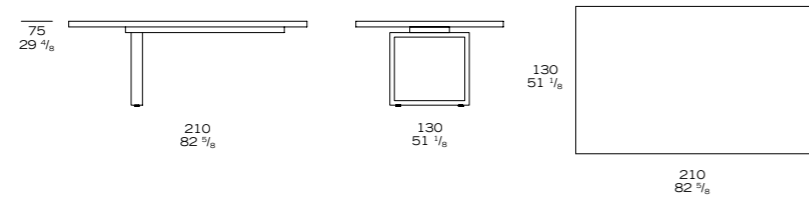

FINISHES

top:
ebony EC
american walnut NR
wenge WG
structure:
polished chrome CL

END ELEMENT

L.TI.011.02

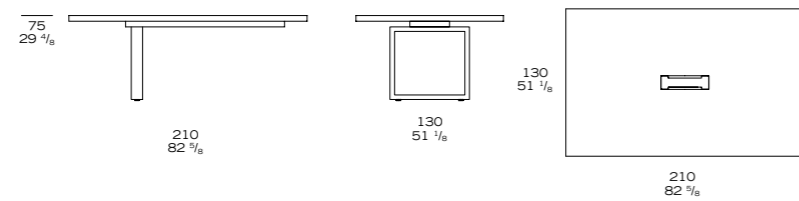

FINISHES

top:
ebony EC
american walnut NR
wenge WG
structure:
polished chrome CL

CENTRAL ELEMENT

L.TI.012.01

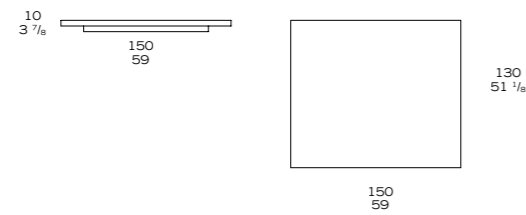

FINISHES

top:
ebony EC
american walnut NR
wenge WG
structure:
polished chrome CL

CENTRAL ELEMENT

L.TI.012.02

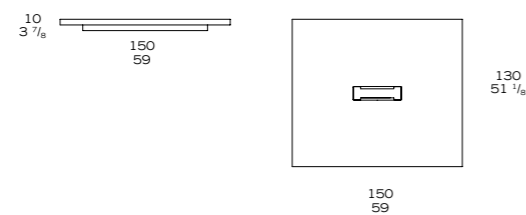

FINISHES

top:
ebony EC
american walnut NR
wenge WG
structure:
polished chrome CL

Modular tables

CENTRAL ELEMENT

L.TI.012.03

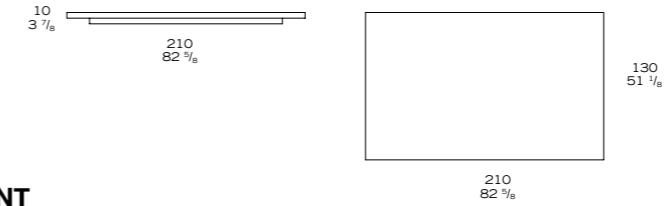

FINISHES

top:
ebony EC
american walnut NR
wenge WG
structure:
polished chrome CL

CENTRAL ELEMENT

L.TI.012.04

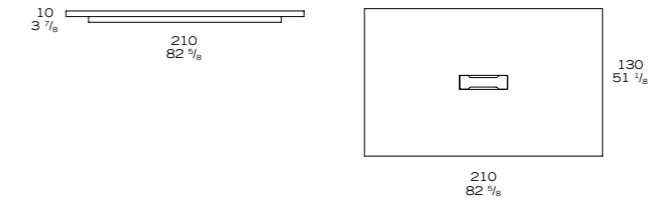

FINISHES

top:
ebony EC
american walnut NR
wenge WG
structure:
polished chrome CL

END LEG

L.TI.013.01

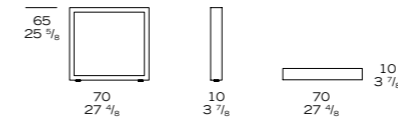

FINISHES

structure:
polished chrome CL

CENTRAL LEG

L.TI.014.01

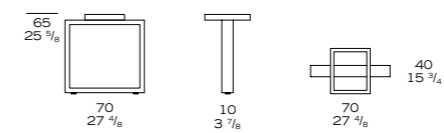

FINISHES

structure:
polished chrome CL

Any design requirement can be satisfied by choosing customized materials, finishes and dimensions.

Any design requirement can be satisfied by choosing customized materials, finishes and dimensions.

Cabinets

CABINET / 2 drawers - 1 filing

L.TI.020.01

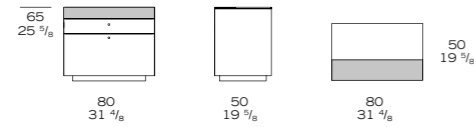

FINISHES

structure:
ebony EC
american walnut NR
wenge WG

drop-front drawers:
leather P3 black, moka

drawers and filing
lacquered according to
leather color tone

FINISHES

structure:
ebony EC
american walnut NR
wenge WG

drop-front drawers:
leather P3 black, moka

drawers and filings
lacquered according to
leather color tone

CABINET / 4 drawers - 2 filings

L.TI.020.02

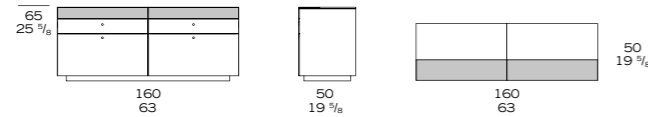

FINISHES

structure:
ebony EC
american walnut NR
wenge WG

drop-front drawers:
leather P3 black, moka

drawers and filings
lacquered according to
leather color tone

CABINET / 6 drawers - 3 filings

L.TI.020.03

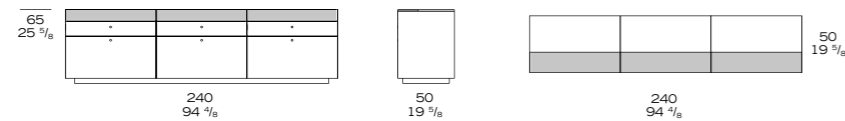

FINISHES

structure:
ebony EC
american walnut NR
wenge WG

drop-front drawers:
leather P3 black, moka

veneered inside cabinet;
drawer lacquered according
to leather color tone

CABINET / 1 drawer - 1 shelf

L.TI.020.04

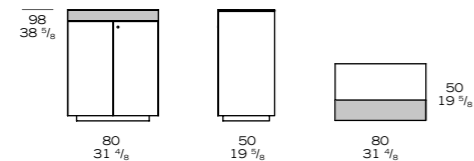

FINISHES

structure:
ebony EC
american walnut NR
wenge WG

drop-front drawers:
leather P3 black, moka

CABINET / 2 drawers - 2 shelves

L.TI.020.05

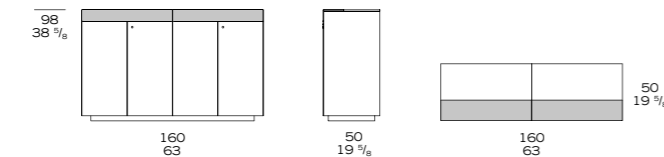

Cabinets

CABINET / 3 drawers - 3 shelves

L.TI.020.06

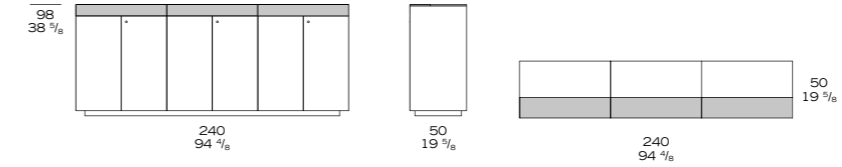

FINISHES

structure:
ebony EC
american walnut NR
wenge WG

drop-front drawers:
leather P3 black, moka

veneered inside cabinet;
drawers lacquered
according to leather
color tone

CABINET / 1 shelf

L.TI.021.01

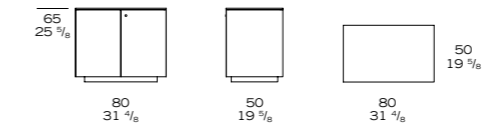

FINISHES

structure:
ebony EC
american walnut NR
wenge WG

veneered inside cabinet

CABINET / 2 shelves

L.TI.021.02

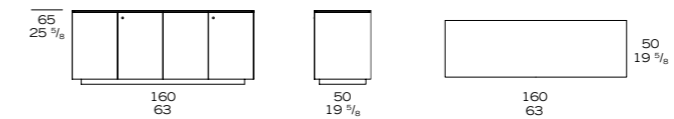

FINISHES

structure:
ebony EC
american walnut NR
wenge WG

veneered inside cabinet

CABINET / 3 shelves

L.TI.021.03

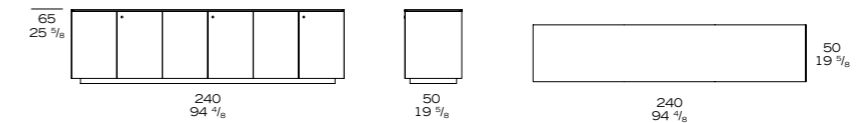

FINISHES

structure:
ebony EC
american walnut NR
wenge WG

veneered inside cabinet

CABINET / 2 shelves

L.TI.021.04

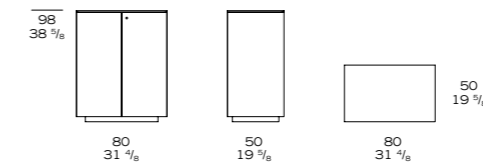

FINISHES

structure:
ebony EC
american walnut NR
wenge WG

veneered inside cabinet

Any design requirement can be satisfied by choosing customized materials, finishes and dimensions.

Any design requirement can be satisfied by choosing customized materials, finishes and dimensions.

Cabinets

CABINET / 4 shelves

L.TI.021.05

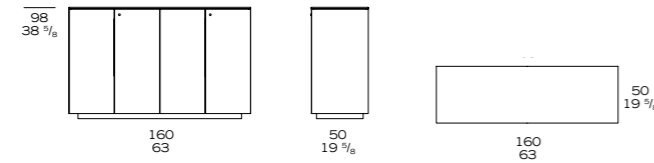

FINISHES

structure:
ebony EC
american walnut NR
wenge WG

veneered inside cabinet

CABINET / 6 shelves

L.TI.021.06

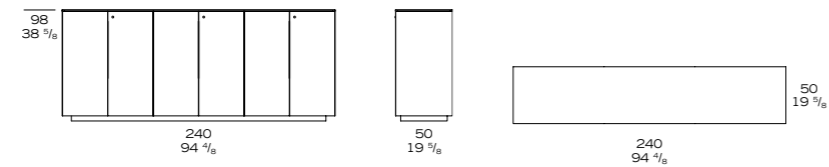

FINISHES

structure:
ebony EC
american walnut NR
wenge WG

veneered inside cabinet

Modular cabinets

CABINET / 2 drawers - 1 filing - without skirting

L.TI.022.01

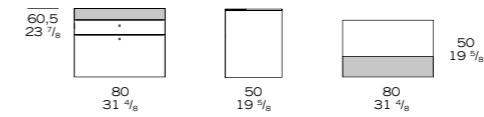

FINISHES

structure:
ebony EC
american walnut NR
wenge WG

drop-front drawers:
leather P3 black, moka

drawers and filing
lacquered according to
leather color tone

CABINET / 1 drawer - 1 shelf - without skirting

L.TI.022.02

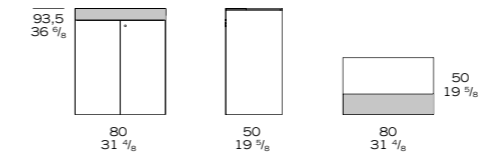

FINISHES

structure:
ebony EC
american walnut NR
wenge WG

drop-front drawers:
leather P3 black, moka

veneered inside cabinet;
drawer lacquered according
to leather color tone

CABINET MODULAR ELEMENT / 1 shelf - without top and skirting

L.TI.023.01

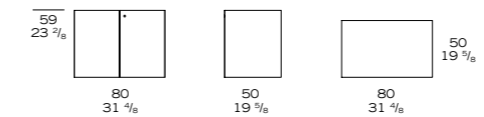

FINISHES

structure:
ebony EC
american walnut NR
wenge WG

veneered inside cabinet

CABINET MODULAR ELEMENT / 2 shelves - without top and skirting

L.TI.023.02

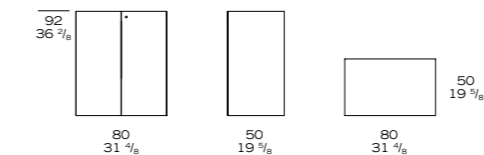

FINISHES

structure:
ebony EC
american walnut NR
wenge WG

veneered inside cabinet

Any design requirement can be satisfied by choosing customized materials, finishes and dimensions.

Any design requirement can be satisfied by choosing customized materials, finishes and dimensions.

Modular cabinets

SKIRTING

L.TI.024.01

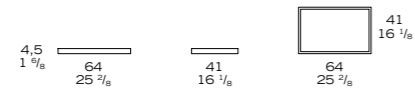

FINISHES

structure:
varnished in chrome
finish VC

L.TI.024.02

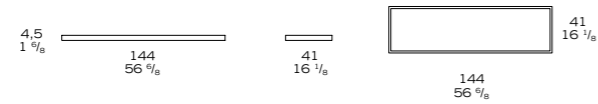

L.TI.024.03

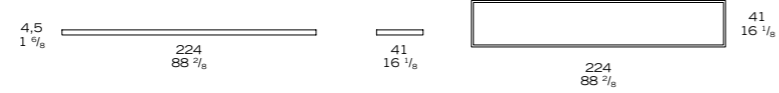

L.TI.024.04

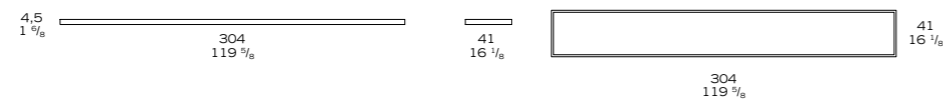

Modular cabinets

SHELF

L.TI.025.01

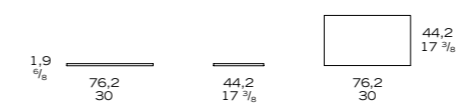

FINISHES

structure:
ebony EC
american walnut NR
wenge WG

TOP

L.TI.026.01

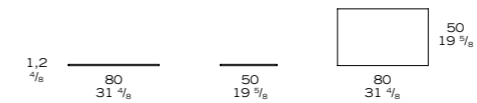

FINISHES

structure:
ebony EC
american walnut NR
wenge WG

L.TI.026.02

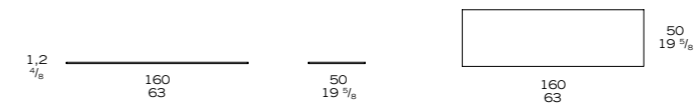

L.TI.026.03

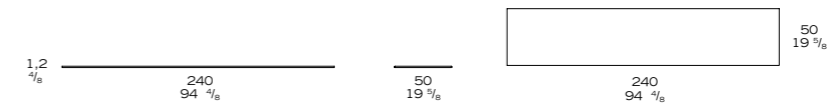

L.TI.026.04

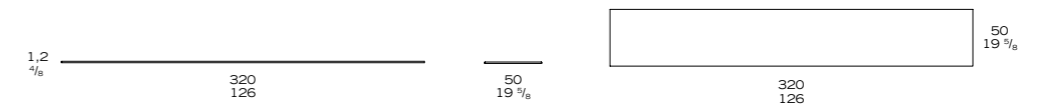

Accessories

LEATHER DESK PAD

L.TI.030.01

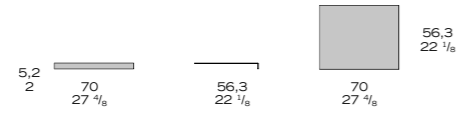

FINISHES

leather P3 black, moka

LEATHER DESK PAD

L.TI.030.02

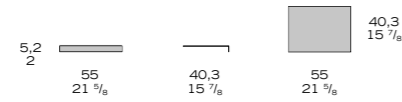

FINISHES

leather P3 black, moka

LEATHER DESK PAD

L.TI.030.03

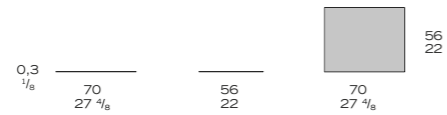

FINISHES

leather P3 black, moka

LEATHER DESK PAD

L.TI.030.04

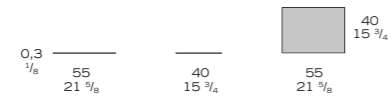

FINISHES

leather P3 black, moka

Accessories

DRAWER INTERNAL DIVIDER

L.TI.031.01

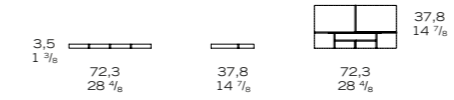

FINISHES

lacquered according to leather color tone

DRAWER INTERNAL DIVIDER

L.TI.031.02

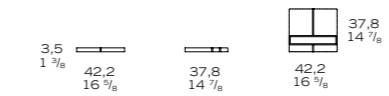

FINISHES

lacquered according to leather color tone

Note on samples

The samples shown here may differ slightly from the actual product. Upon request we can send a sample book with the actual materials used. As far as wood is concerned, even the real samples, owing to the natural qualities of wood, do not guarantee that the used materials match exactly the samples. Furthermore, we cannot guarantee that items produced using the same type of wood will always display uniformity in colour and grain. Exposure to light and the natural ageing process mean that wood is subject to changes in colour.

Materials & finishes

Metals

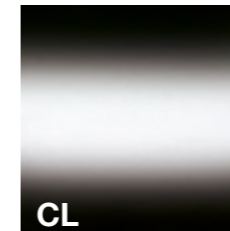

Polished
chrome



Varnished in
chrome finish

Woods

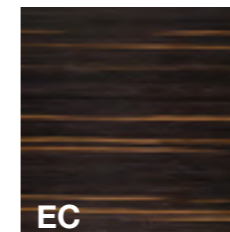

Ebony

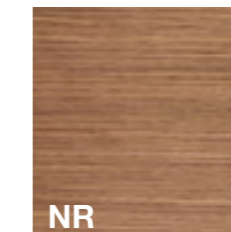

American walnut



Wenge

Leathers

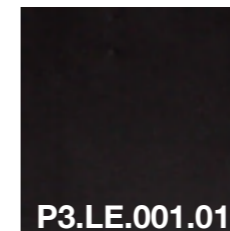

Black

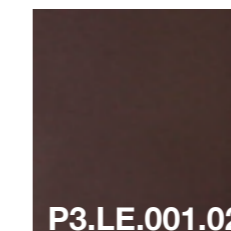

Moka

Technical notes

Desks

The tops, with 90° edges, are made of 50 mm veneered light plywood panels class E1, veneered in ebony, walnut and wenge and finished with a matt transparent polyurethane paint with semi-open pore. The structure is made of tubular steel with a 30x50 mm section. The leg is made of a 40x100 mm steel frame with a polished chrome finish. The height of the top is 750 mm. The desks are fitted for electrification and cabling directly from the top.

Desk cabinets

With an height of 650 mm and three separate compartments, the service cabinets are completely veneered in ebony, walnut or wenge. The main compartment has a leather upholstered, drop-front stationary drawer in black or dark brown with a push & pull latch that covers an extractable stationary drawer that can be customized. Locks with black-moka leather covered keys open drawers with concealed runners and doors with soft closing system. The insides are made of wood with a black lacquered finish; the bases are made of steel with a epoxy powder coated chrome finish. The perimetral elements have a 45° junction; the clever horizontal combination of the grain of the veneers allows the volumes to be perceived as an unicum.

Tables & modular tables

With a top height of 750 mm, they can be single tables or modular configurations based on top and structure modules. The tops are made of veneered light plywood panels class E1 of 50 mm thickness with 90° edges, veneered in ebony, walnut and wenge and finished with a matt transparent polyurethane paint, with semi-open pore. They can be fitted, upon request, for cabling up to the top by means of an outlet compartment with an integrated flap with the same finish as the top. The supporting structures are made of a steel pipe with a 30x50 mm section frame linked to the 40x100 mm steel pipe legs that can be supplied in the standard version or fitted for cabling. Structures, frames and legs are made of steel with a polished chrome finish.

Cabinets

The collection presents three types of cabinets with different functions, all free standing and finished on the 4 sides: cabinets to be placed near a desk but independent from it, cabinets with a drop-front drawer and two doors; cabinets with two doors and shelves that can be adjusted in height. The frames are made of 18 mm veneered and varnished MDF with the same finishes as the desks. The perimetral elements have a 45° junction and the clever horizontal combination of the grains of the essences allows the veneered parts to be perceived as a continuum. The doors are made of 18 mm MDF, veneered like the tops with an horizontal orientation of the grain of the essences; they are fitted with high load hinges with soft closing system and a lock with a leather covered key. The bases are made of steel with an epoxy powder coated chrome finish; the feet can be adjusted in height from within the container by means of an allen key.

Desk pad

Desks and tables can be fitted with desk pads upholstered in black or dark brown matt leather. The internal structure, made of aluminium, allows for extreme lightness while maintaining the required rigidity. They are available with an edge cover, thus creating an aesthetic continuum with the drop-front drawer, or in the classic rectangular shape.

Eco sustainability and environmental protection

Logica, always sensitive to the issues of environmental protection, uses completely eco-friendly materials only: all the elements of the furniture and all the production processes to which they are subjected allow for a complete and real recyclability of each item. The materials made of wood fibre used by Logica are produced exclusively by certified companies that meet the requirements of the FSC (Forest Stewardship Council) and PEFC (Programme for the Endorsement of Forest Certification Schemes) reference schemes; Logica therefore works only with materials deriving from cultivation and planned deforestation, not from uncontrolled deforestation.

Ethical work

Logica is certified SA8000, Ethical Work. To obtain this certification it implements various organizational and productive processes aimed at a total transparency of its work that includes the respect for human rights and of worker's rights without any kind of discrimination. Logica is accountable for the entire production chain for the compliance with the rules of an ethical work and ensures that the finished product sold under its brand is the result of a management that is, from beginning to end, environmentally, socially, ethically and economically sustainable.

Safety and quality

Logica uses only chipboard or MDF that comply with the rules regarding the content of formaldehyde for Class 1 standards. The metal parts of the furnishings are epoxy coated and comply with the requirements of the UNI EN ISO 1520 and UNI ISO 9227 standards. The desks comply with the dimensional parameters dictated by the UNI EN 527-1 standard on safety; they also comply with the UNI 8594 standard in regard with the bending of the tops, the UNI EN 527 standard for vertical and horizontal resistance, and falling, as well as the UNI 9086 one regarding the side impact. The containers comply with the general safety rules of the UNI EN 14073-2 standard, in addition to the requirements of UNI EN 14074 and UNI 8606 ones in regards with the maximum duration and capacities.

About Logica

Office living

Founded in 1989 and taken over by the Interna Group in 2006, the Logica name is now considered a reference for the supply of interior design solutions for offices and congress centres. Right from the start of its story, and even more so today, the Logica trademark has been proposed to those who operate in the office sector, its mission being to supply high quality products and a reliable, personalised service. This has helped create a company which is extremely versatile when seeking, proposing and creating tailor-made solutions designed around its clients, which means freedom from the limits normally set by mass-produced products.

The Interna Group, on the other hand, has been operating for more than 20 years in the luxury interior design sector, and boasts an international reputation in the design of turnkey projects for hotels, restaurants, congress centres, boutiques, private residences, cruise liners and yachts. With the Logica trademark, the company intends diversifying their range of services on offer, as well as accepting the challenge of supplying a personal touch when furnishing contemporary work spaces. Today's office spaces and congress centres require, or rather demand, certain specific characteristics, which range from versatility of the areas involved, to the ability of being able to host a variety of operational requirements.

To respond to these requirements, work environments proposed by Logica are essential, yet warm and personalised, with elegant yet extremely functional forms, made entirely from only solid, quality materials.

Turn-key

Logica offers a turnkey service for furnishings, finishes and interior decorating. It includes the executive design, production, logistics, installation, testing and an after-sales service, all carried out with full respect for the quality, price and delivery terms formally agreed upon. The company aims particularly at those clients who require not only high quality products - standard or tailor made - but also service with a high technological content.

Quality certifications

Turn-key projects have a major environmental and social impact which means that manufacturers should be called upon to follow strict policies regarding environment and employment. Our Group has always been sensitive to the issue of fair and sustainable growth through its integrated certified system Quality ISO 9001 | Environment ISO 14.001 | Ethics SA 8000.

Logica works to ensure that the process of globalisation is carried out in full recognition of human rights, international labour laws and environmental protection.



Registered trademark and designs

Logica is a registered Trademark ® since 1989.

All Logica items are copyrighted and covered by registered designs as to prevent any possible rights infringement and ensure the maximum protection to its clients.

Interna act under the following specialized companies

Interna Holding Spa

Holding company of the entire Interna Group; administrative, financial, purchasing, logistics, human resources services for all companies of the Group.

Interna Contract Spa

One-off furnishing products for unique turnkey projects covering the whole luxury market: hotels, bars & restaurants, museums, offices, stores, homes, yachts, casinos, health farms, private clinics, cruise ships and yachts. A complete package of services including financing, planning, production, project management, logistics, installation and after sale assistance.

Interna Collection Srl

An innovative range of furniture and furnishings for the hospitality and contract industry, involving over 300 concepts. Three different high profile design lines, Traditional, Transitional and Contemporary and four dedicated collections: Les Grands Classiques de Jacques Garcia, Anglodutch by FG stijl, Bedroom Stories, five new hotel room concepts, Echoes by Khuan Chew. Extreme flexibility: all the items can be customized in terms of materials, finishes and dimensions.

Interna Asia Pacific, Co.Ltd

Implementation of Interna products and services on the Asian market. Turn key projects, one-off furnishing products, standard furnishings, office furniture.

Logica Srl

One-off furnishing solutions for the world of the office to satisfy any design requirement. Design collections for operative and executive offices, a presidential line, all in accordance with international regulations regarding materials and functional features.

Interna Real Estate Srl

A complete package of services - real estate brokerage, project development, valuation & due diligence, financial engineering, master & space planning, operator selection, project management, real estate consulting - to conceive and successfully execute any real estate project, especially in the hotel sector.

We had the pleasure to work with





HEADQUARTERS

via G. Galilei, 9/A
33010 Tavagnacco
(Udine) Italy
Phone: +39 0432 643 211
www.logica.eu | logica@logica.eu
www.interna.it | interna@interna.it

LOGICA ASIA PACIFIC

425 Yanping Lu, Continuity Building,
Unit 308 | Jing An District 200042
Shanghai P. R. of China
Phone +86 (0)21 62712977
www.interna.asia | interna.asia@interna.it

WORLDWIDE OFFICES

Australia, Austria, Finland,
France, Germany, India, Japan,
Morocco, New Zeland, Russia,
Singapour, Spain, The Netherlands,
UAE, UK, USA, Vietnam

This volume is edited by Derna Del Stabile Travan
Photoshootings and post-production: Emanuele Paravano for Interna Holding
English: Francesca Vidoni for Interna Holding
Printed in Italy by Grafiche Antiga | March 2015
by Logica, Tavagnacco (Ud), Italy 2015. All rights reserved ©